

TC-758

E Model
US Model
Canadian Model



AUTO REVERSE STEREO TAPECORDER

SPECIFICATIONS

Power Requirements:	AC 100, 110, 120, 127, 220 or 240 V, 50/60 Hz, 60 W (E Model) 120 V, 60 Hz, 60 W (USA, Canada Model)	Outputs:	LINE OUT (2) Impedance: 100 k Ω Level: -5 dB (0.44 V) with 100 k Ω load HEADPHONES Impedance: 8 Ω AC OUTLET Unswitched 300 W
Track System:	Four-track two-channel stereo and monaural	REC/PB (DIN) Connector (E Model):	Input impedance: 3.9 k Ω Output impedance: 8.2 k Ω
Reels:	270 mm (10 $\frac{1}{2}$ inches) or smaller	Heads:	Record : RF140-2902 Playback: RF140-4202 Erase : EF18-2902A2 (2)
Tape Speed:	19 cm/s (7 $\frac{1}{2}$ ips), 9.5 cm/s (3 $\frac{3}{4}$ ips)	Motors:	Capstan: IC-624G (AC servo-controlled) Reel : IC-638R (2)
Recording Time:	6 hours total at 9.5 cm/s (3 $\frac{3}{4}$ ips), stereo recording, with 1,100 m (3360 ft.) tape of 270 mm (10 $\frac{1}{2}$ inch) reel	Semiconductors:	1 IC, 2 FETs, 81 transistors, 7 $\frac{1}{2}$ diodes
Frequency Response:	According to NAB standards 20~30,000 Hz at 19 cm/s (7 $\frac{1}{2}$ ips) 20~20,000 Hz at 9.5 cm/s (3 $\frac{3}{4}$ ips) (with normal tape) 20~25,000 Hz at 19 cm/s (7 $\frac{1}{2}$ ips) 20~17,000 Hz at 9.5 cm/s (3 $\frac{3}{4}$ ips)	Dimensions:	451 (w) x 435 (h) x 221 (d) mm 17 $\frac{3}{4}$ (w) x 17 $\frac{1}{8}$ (h) x 8 $\frac{3}{4}$ (d) inches
Signal-to-Noise Ratio:	56 dB (with SONY SLH tape) 53 dB (with normal tape)	Weight:	24.5 kg, 53 lb 10 oz
Wow and Flutter:	0.05 % (RMS) weighted at 19 cm/s (7 $\frac{1}{2}$ ips) 0.08 % (RMS) weighted at 9.5 cm/s (3 $\frac{3}{4}$ ips)		
Overall Distortion:	1.2 %		
Record Bias Frequency:	Approximately 160 kHz		
Inputs:	MIC (2) Impedance: low Maximum sensitivity: -72 dB (0.19 mV) LINE IN (2) Impedance: 100 k Ω Maximum sensitivity: -22 dB (60 mV)		

SONY[®]

SERVICE MANUAL

SECTION 1 OUTLINE

1-1. BLOCK DIAGRAMS

Amplifier Section

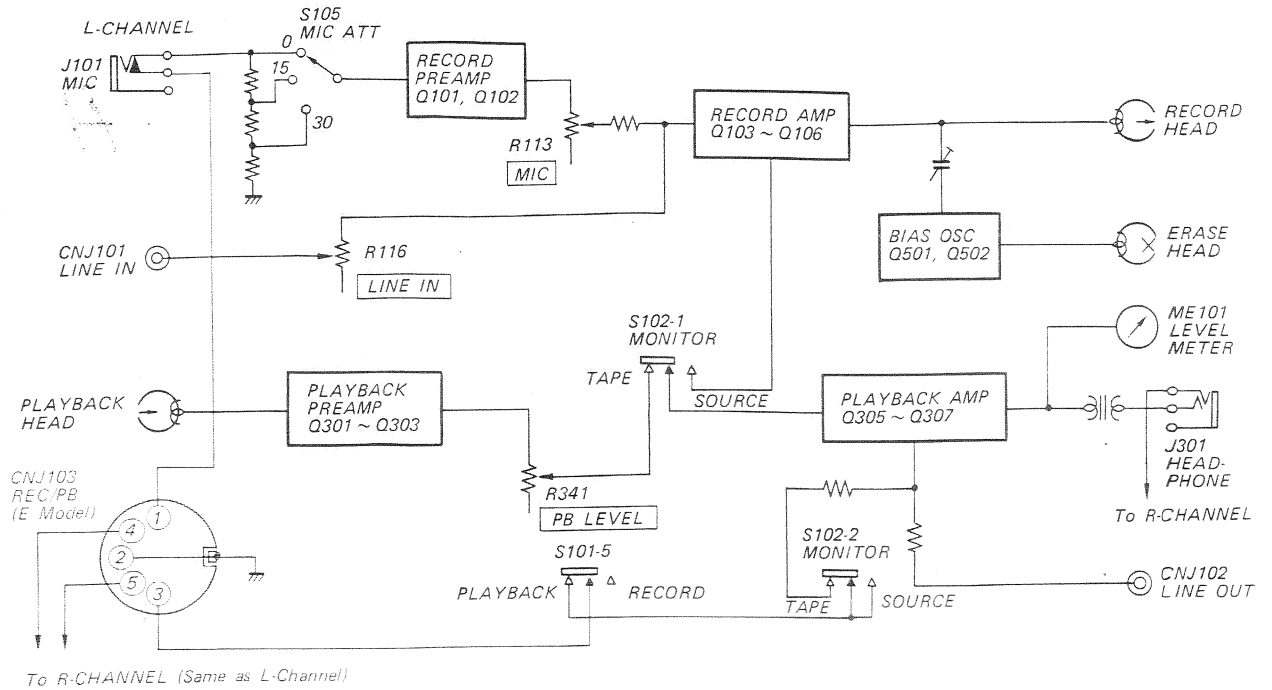

System Control Section

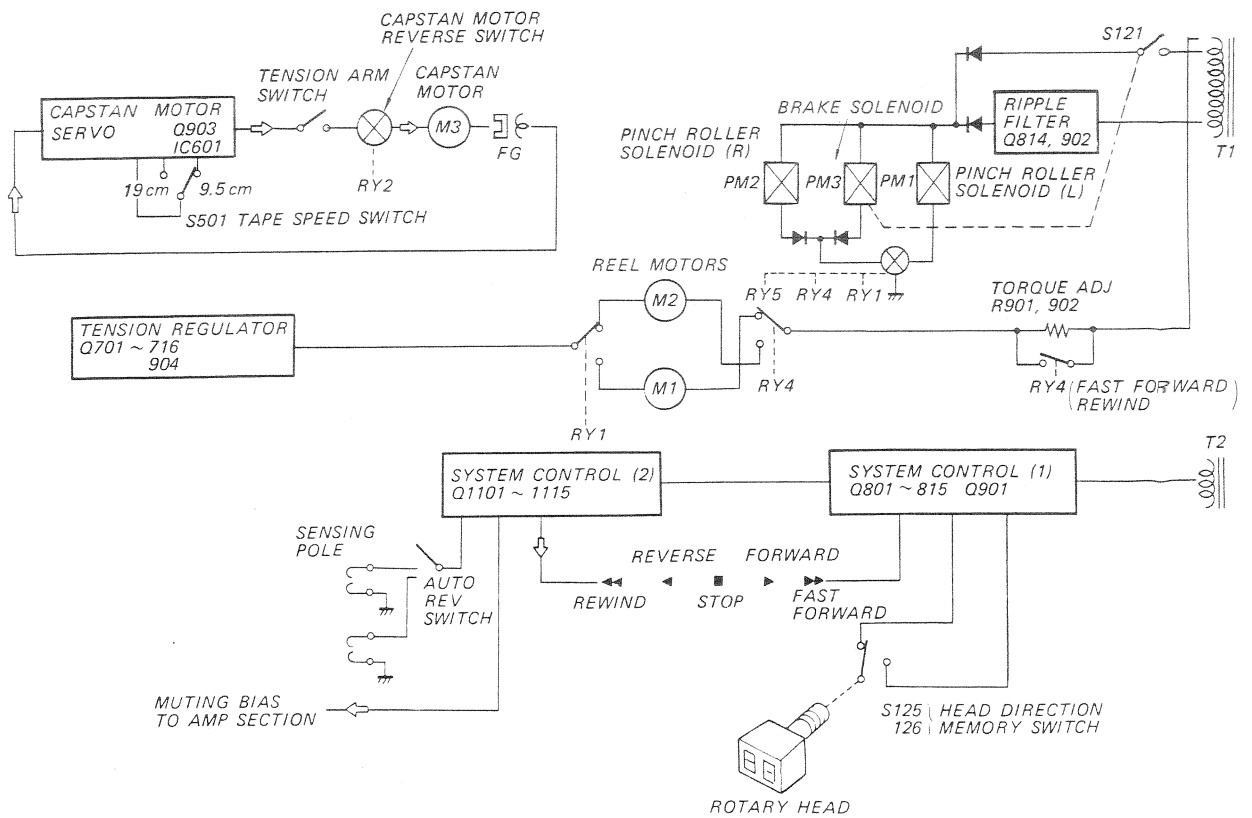

1-2. EXTERNAL VIEW

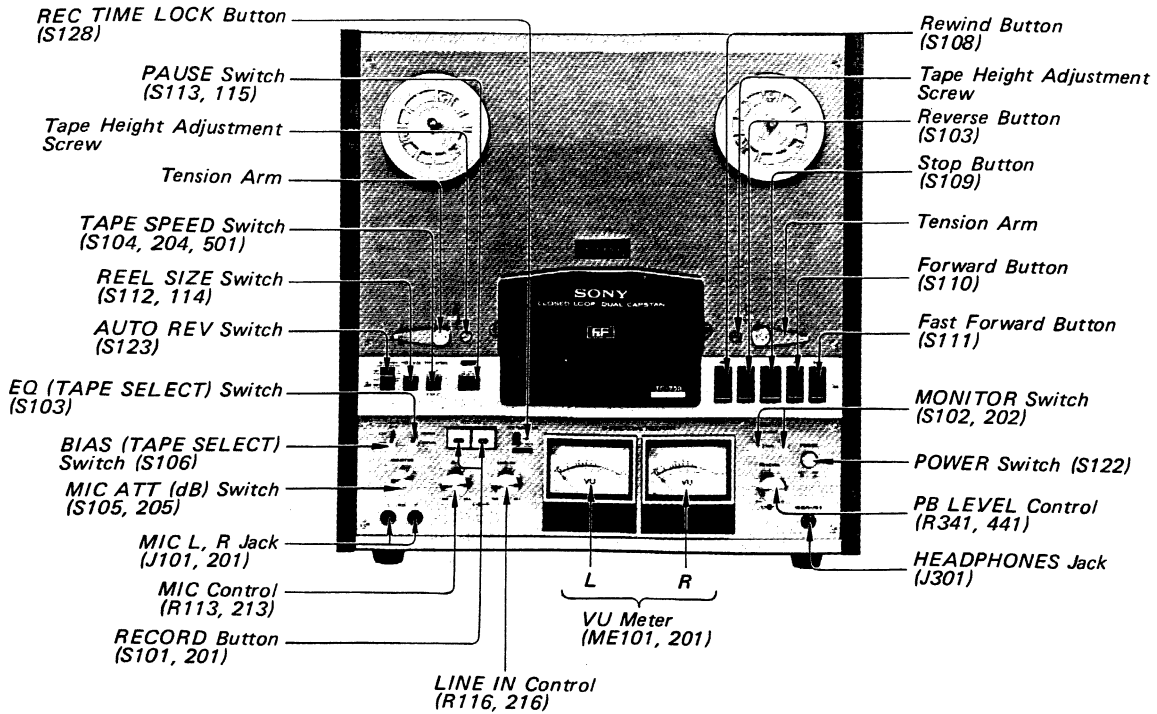

1-3. INTERNAL VIEW (1)

For E, USA Model

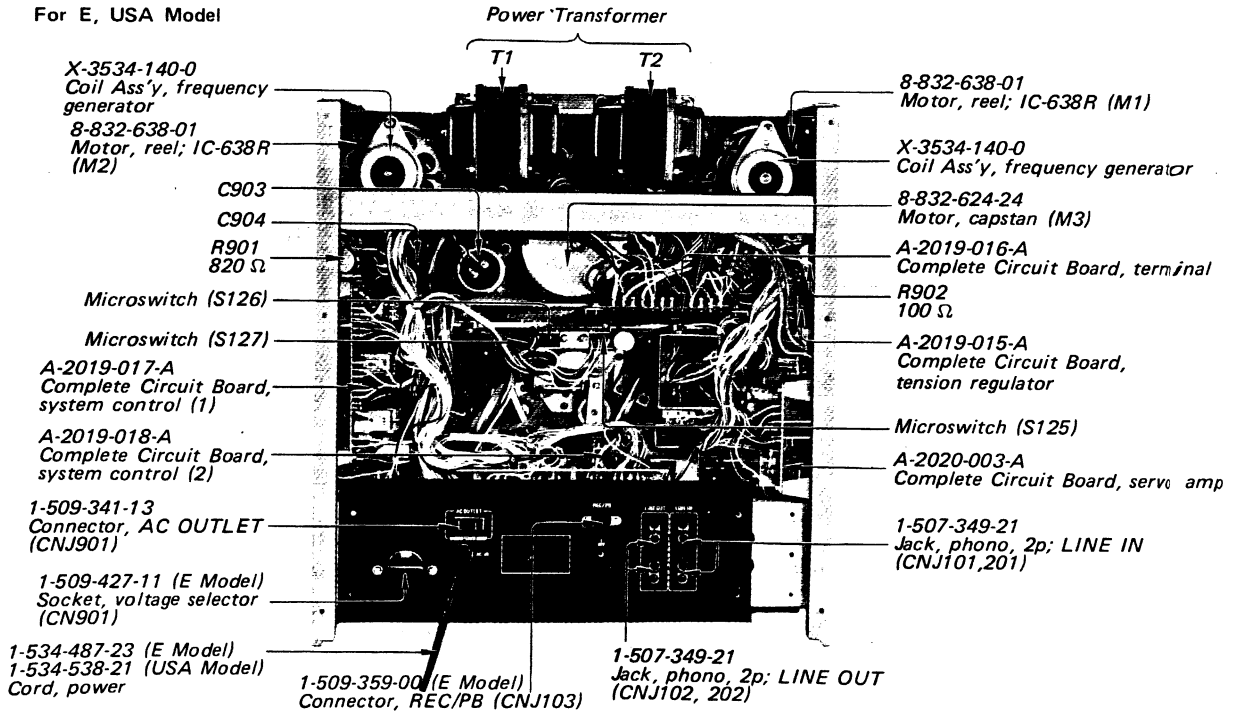

For Canada Model

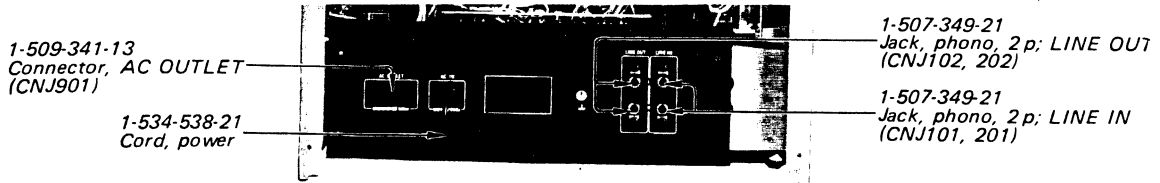

1-4. INTERNAL VIEW (2)

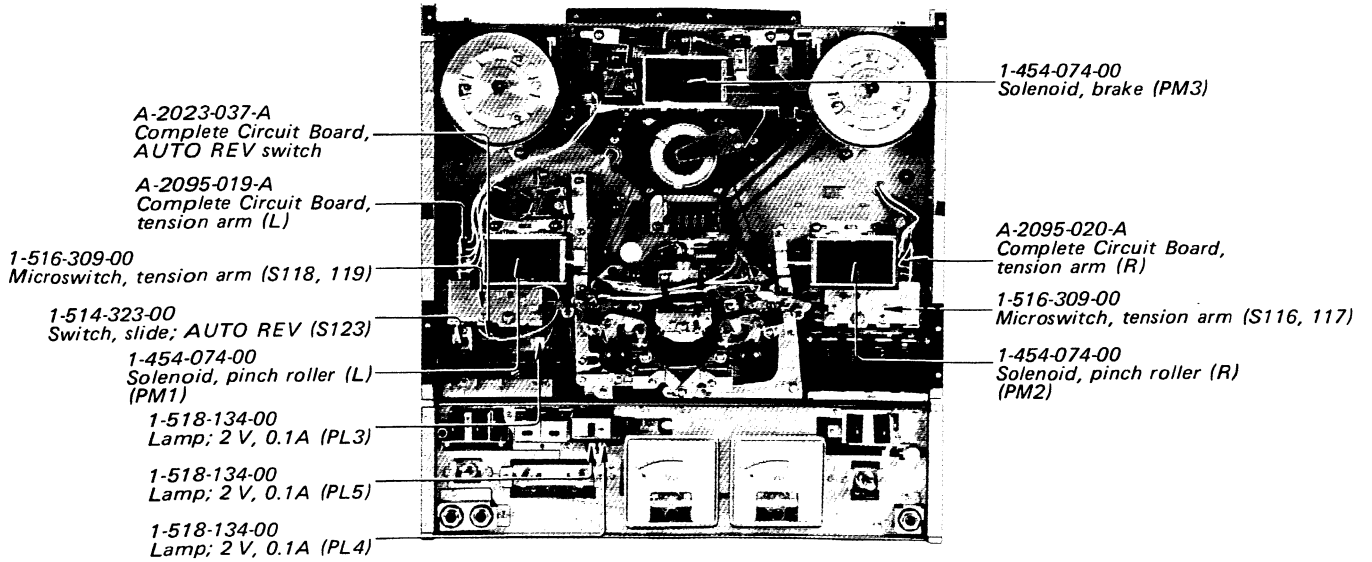

1-5. INTERNAL VIEW (3)

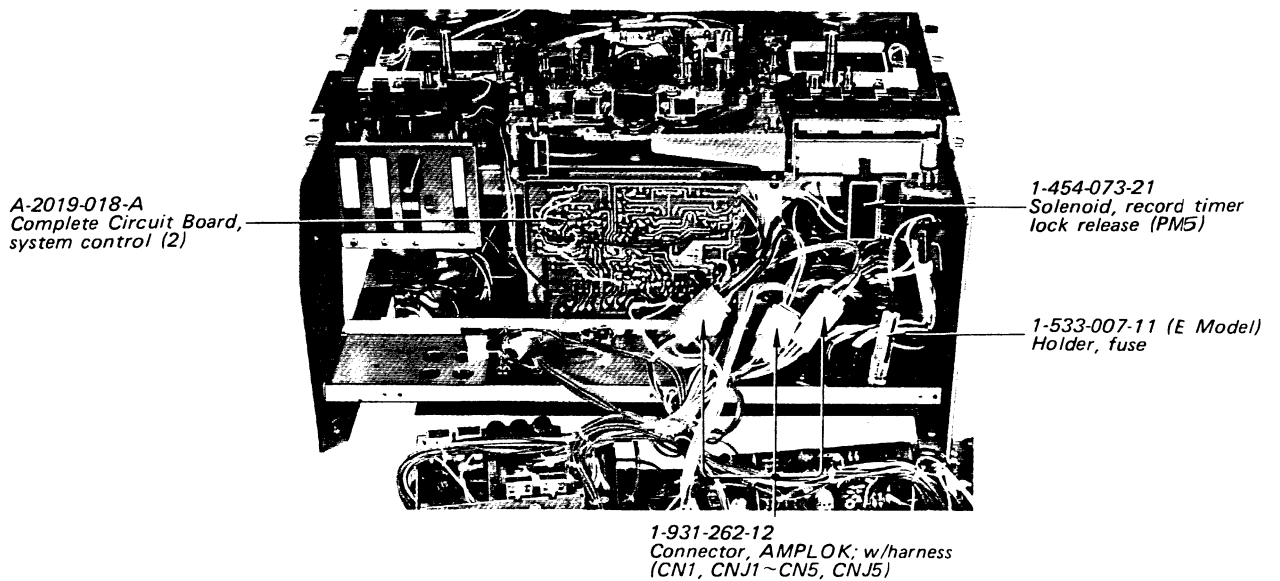

1-6. INTERNAL VIEW (4)

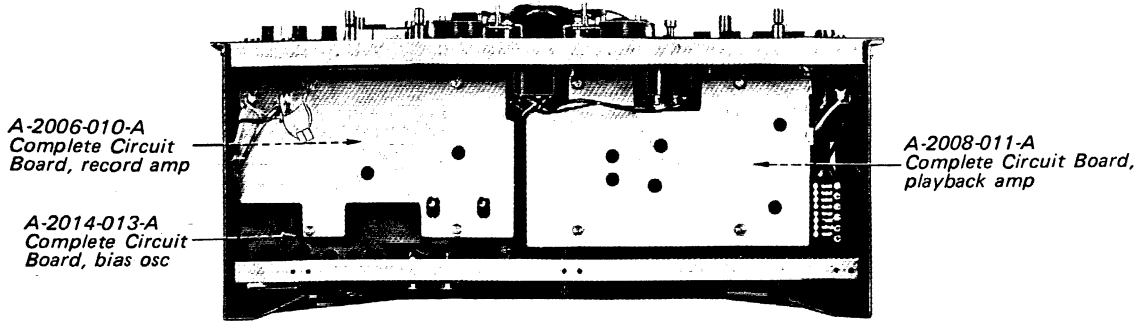

1-7. INTERNAL VIEW (5)

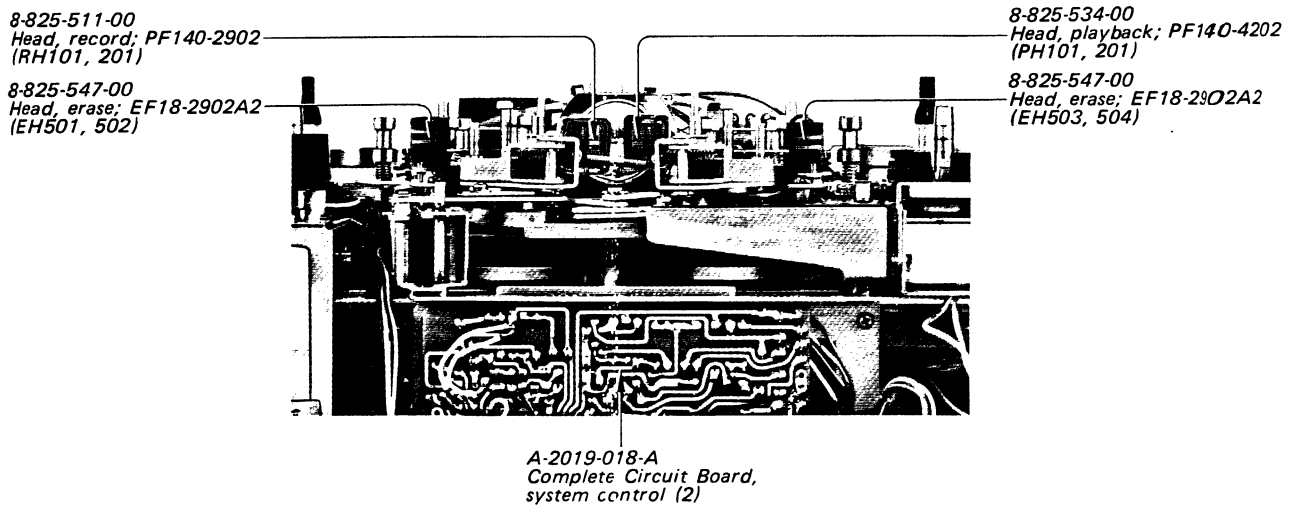

SECTION 2
DISASSEMBLY

(1) Case Removal

Remove two screws RK 4x33, two screws RK 4x35, four washers and four fiber washers from both sides and six screws P 4x14 and six spacers from the rear.

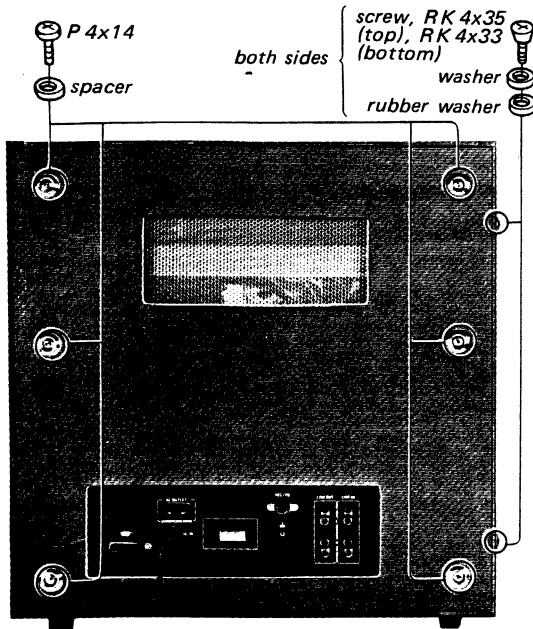

(2) Switch Panel Removal

Remove two screws B 3x6.

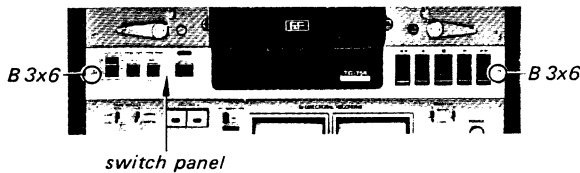

(3) Reel Panel Removal

- Remove the switch panel.
- Remove four screws RK 3x8, four screw ornaments, two tension arm caps and two tension arms from the reel panel.
- Remove two head cover screws and the head cover (A).

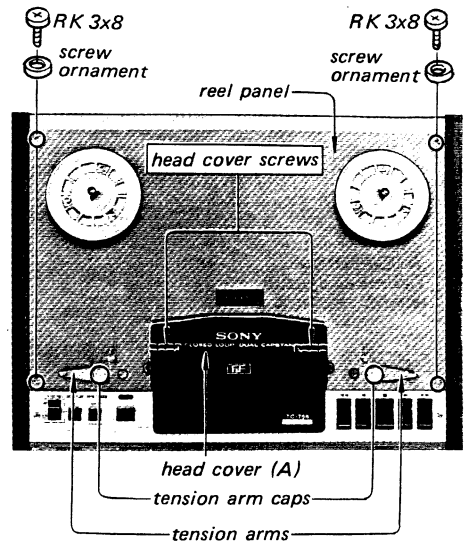

(4) Control Panel Removal

- Remove the switch panel.
- Pull off four lever switch knobs (MONITOR, TAPE SELECT), six control knobs (MIC, LINE IN, PB LEVEL) and rotary switch knob (MIC ATT).
- Remove four screws RK 3x8, four screw ornaments and four washers.

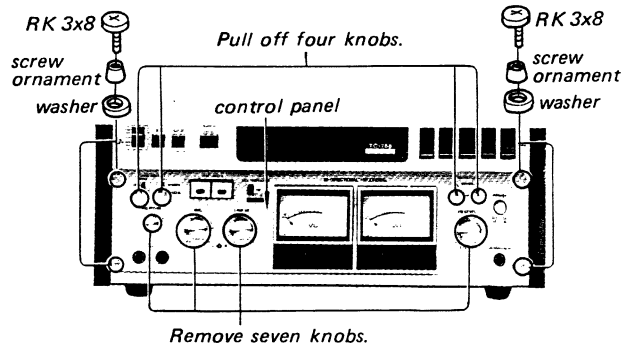

(5) Head Cover (B) Removal

Remove head cover (B) by pulling it forward.

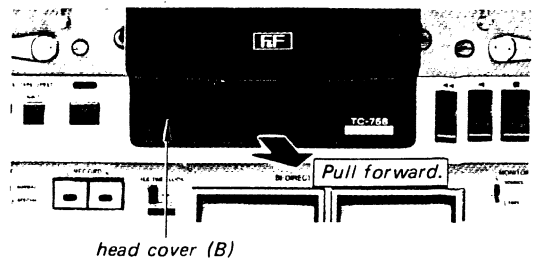

SECTION 3 ADJUSTMENTS

3-1. MECHANICAL ADJUSTMENTS

1. Brake Adjustment (1)

Perform this adjustment for both left and right brakes. After the adjustment, apply locking compound to the adjusted screw.

— Playback mode —

adjustment screw
Adjust the brake adjusting plate for the appropriate brake stroke.

— Right side —

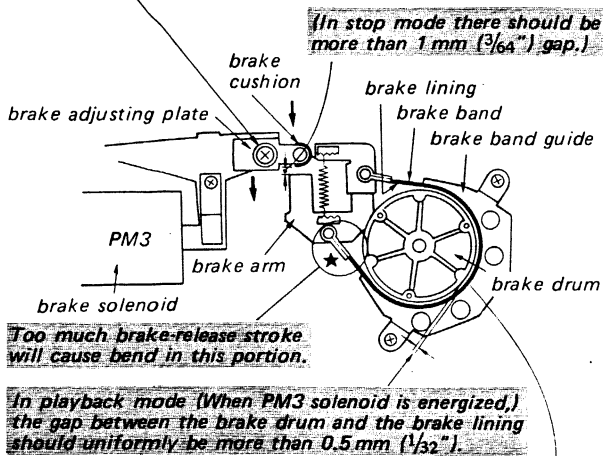

In playback mode (When PM3 solenoid is energized,) the brake band should uniformly contact the brake band guide.

— Left side —

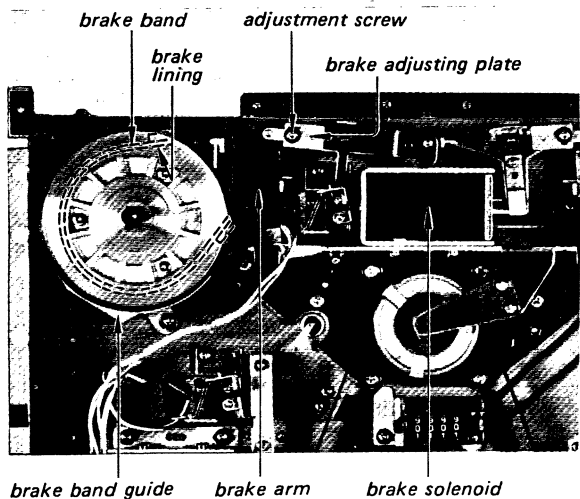

2. Brake Adjustment (2)

Perform this adjustment for both left and right brakes. After the adjustment, apply locking compound to the adjusted screw.

Specification:

Take-up Reel	Supply Reel	Brake Torque
clockwise	counterclockwise	1,800~2,500 g·cm (25.1~34.8 oz·inch)
counterclockwise	clockwise	600~700 g·cm (8.3~9.7 oz·inch)

— Stop mode —

— Right side —

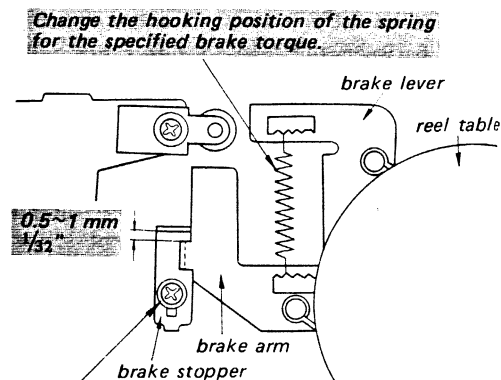

adjustment screw
Adjust the brake stopper for the specified clearance.

— Left side —

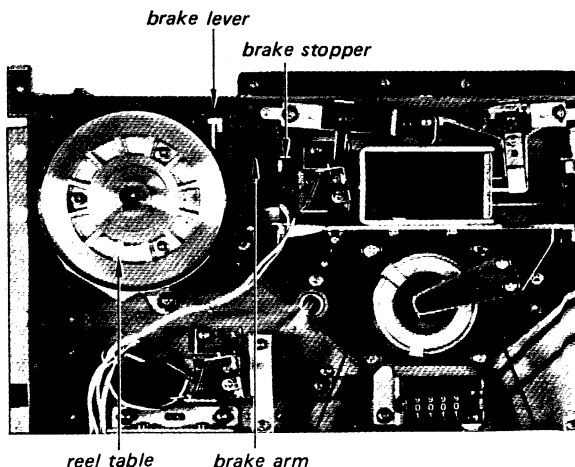

3. Adjustor Adjustment

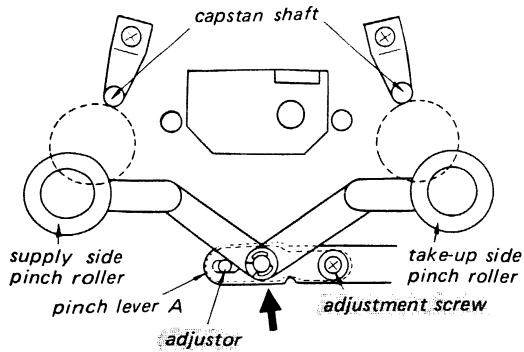

In playback mode and with PAUSE switch to ON, slowly push the pinch lever A in the direction shown by the arrow. When the supply side pinch roller contacts the capstan shaft and starts to rotate, the gap between the take-up side pinch roller and the capstan shaft should be less than 0.5 mm (1/64"), so that the take-up side pinch roller starts rotating slightly after or almost simultaneously with the start of the supply side pinch roller. If necessary, loosen the adjustment screw and adjust the position of the adjustor. Lock the adjustment screw after adjustment.

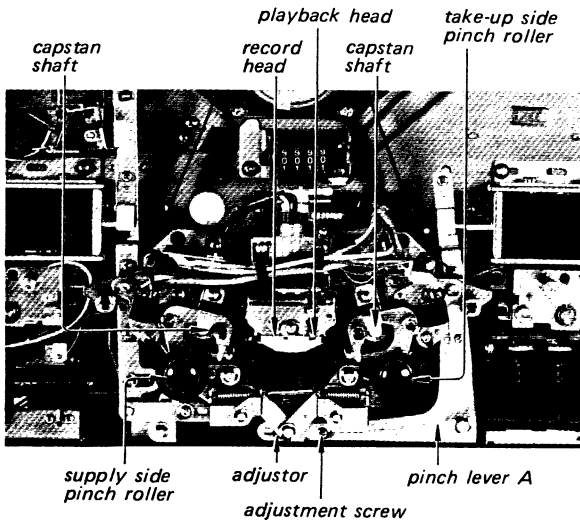

4. Pinch Roller (R) Solenoid (PM2) Position Adjustment

After the adjustment, apply locking compound to the adjusted screws.

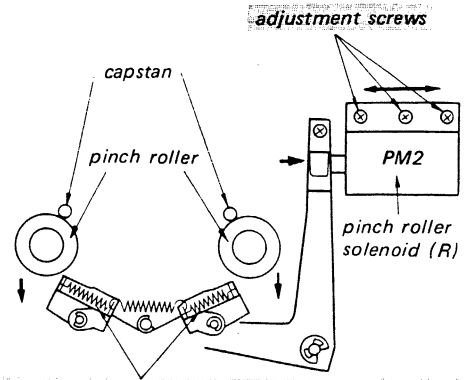

These two springs should expand 0.3~0.5 mm (1/64") longer after the pinch rollers contact the capstans in playback mode. If necessary, adjust the PM2 solenoid position.

Specification as a reference:

Pinch roller pressure: 1000 g ~ 1600 g (2 lb 3 oz ~ 3 lb 8 oz)

pinch roller (R) solenoid (PM2)

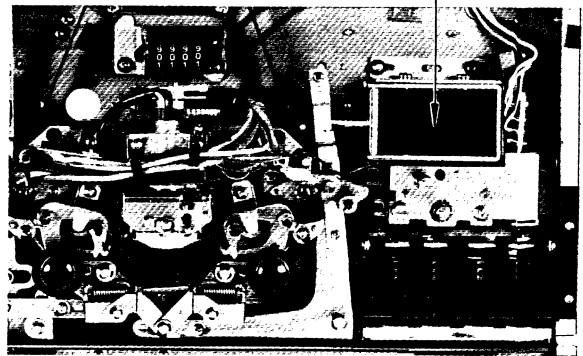

5. Pinch Roller (L) Solenoid (PM1) Position Adjustment

After the adjustment, apply locking compound to the adjusted screws.

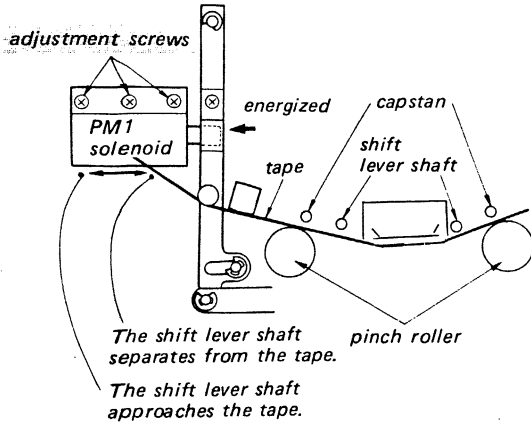

With a tape threaded along the tape path and in playback mode (PM1 solenoid should be energized), turn PAUSE switch ON. At this time the shift lever shafts should allow the tape to contact record and playback heads, and the pinch rollers should separate from the capstans. If necessary, adjust the PM1 solenoid position.

Note: The ferrite head unit should rotate smoothly when the forward and reverse button are pressed alternatively. Move the shift lever shaft forward a little when the heads contact the tape too strong and the head unit does not rotate smoothly. Do not move the shift lever shaft too much, otherwise recording might be degraded due to the click noise when the PAUSE switch is turned on and off.

pinch roller (L) solenoid (PM1)

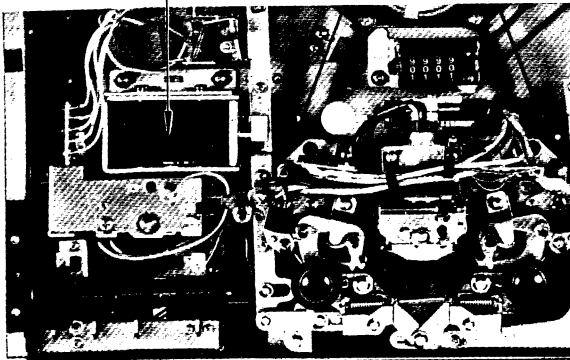

6. RECORD Button Lock Adjustment

After the adjustment, apply locking compound to the adjusted screw.

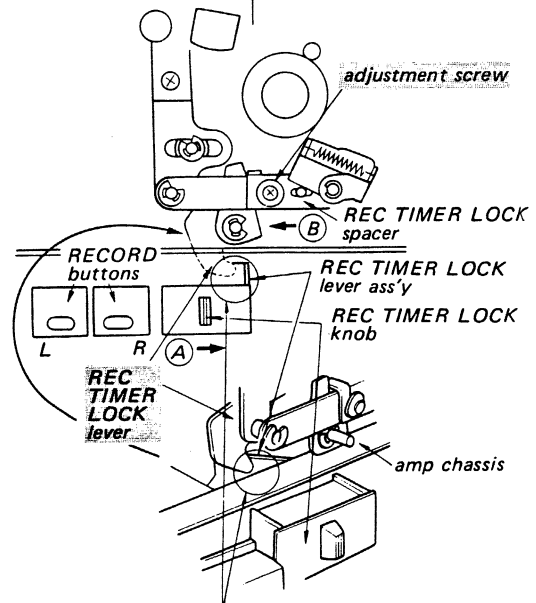
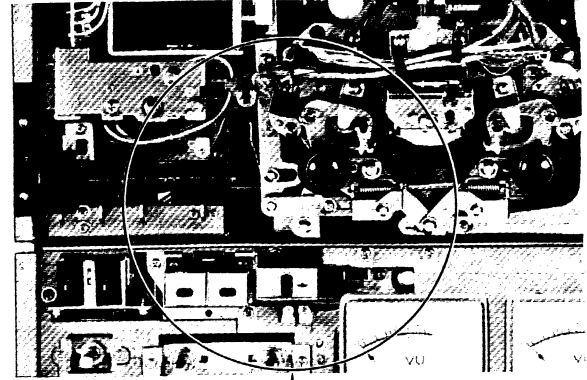

Push L and R RECORD buttons, move REC TIMER LOCK knob in the direction shown by arrow (A) and then push the 'forward' button by holding the REC TIMER LOCK knob.

At this time, REC TIMER LOCK knob and RECORD button should be held and REC TIMER LOCK lever should slightly contact REC TIMER LOCK lever ass'y as shown. If necessary, adjust the REC TIME LOCK spacer.

Note:

After the adjustment, and with the L and R RECORD buttons pushed and the REC TIMER LOCK knob pushed in the direction shown by arrow (A), and also the forward button pushed, make sure of the following functions.

1. Push and hold L and R RECORD buttons and move REC TIMER LOCK knob in the direction shown by arrow (A) and then push forward button. At this time the RECORD buttons should not be released.
2. In stop mode L and R RECORD buttons and REC TIMER LOCK knob should be released.
3. When L and R RECORD buttons are released, REC TIMER LOCK knob cannot be moved in the direction shown by the arrow (A).

7. Actuator Adjustment (1)

Perform this adjustment after the Pinch Roller (L) Solenoid (PM1) Position Adjustment. After the adjustment, apply locking compound to the adjusted screw.

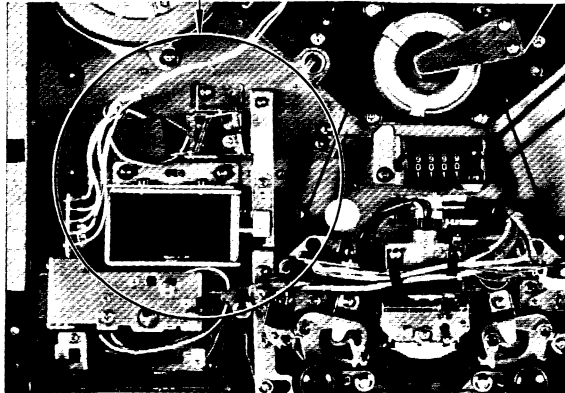
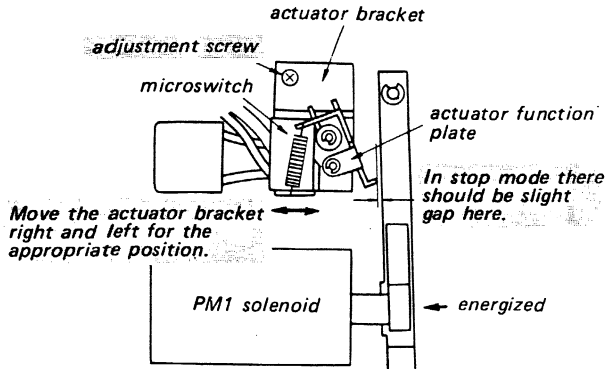

Note: The microswitch should turn OFF (click) in 0.5 to 2 seconds after forward button is pushed.

8. Actuator Adjustment (2)

Perform this adjustment after the Brake Adjustments (1) and (2). After the adjustment, apply locking compound to the adjusted screw.

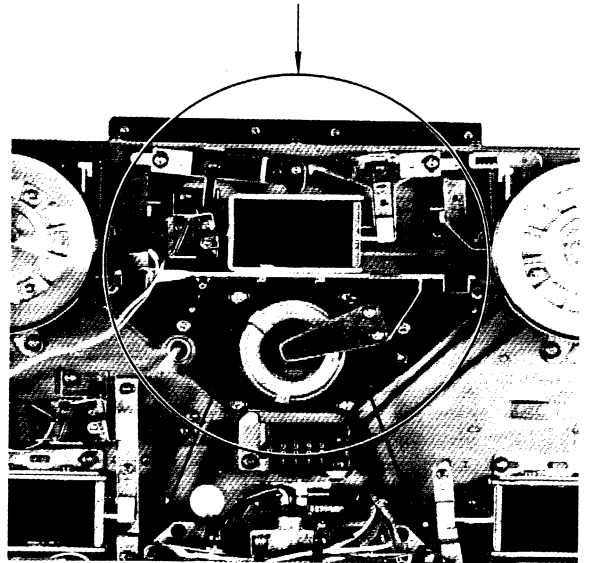
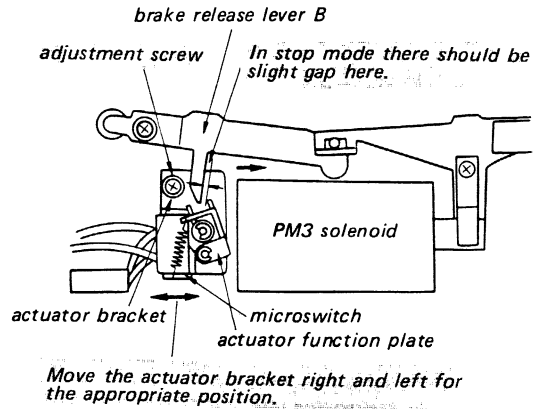

Note: The microswitch should turn ON before the rollers of the brake release levers A and B separate from the brake arms. The microswitch should turn OFF (click) in 0.5 to 2 seconds after forward button is pushed.

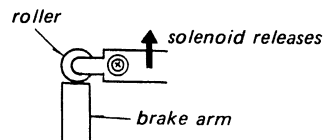

9. Fast Forward and Rewind Back-Tension Adjustment

1. Supply the rated power voltage.
2. Fasten the tension arms with rubber bands as shown, thus activating them.
3. Pull the spring scale at a speed of between 9.5 cm/s to 19 cm/s in the direction shown by the arrow for rewind or fast forward mode with REEL SIZE switch at "7" and "10". Measure the back tension torque for rewind and fast forward modes. Torques should be as shown in the following table.

Specification:

Mode	REEL SIZE Switch	Back-Tension Torque
rewind	10	110 to 140 g·cm (1.53 to 1.95 oz·inch)
	7	80 to 100 g·cm (1.11 to 1.39 oz·inch)
fast forward	10	110 to 140 g·cm (1.53 to 1.95 oz·inch)
	7	80 to 100 g·cm (1.11 to 1.39 oz·inch)

If necessary, adjust the torque by moving the sliders of the adjustable resistor (R901).

— Right side —

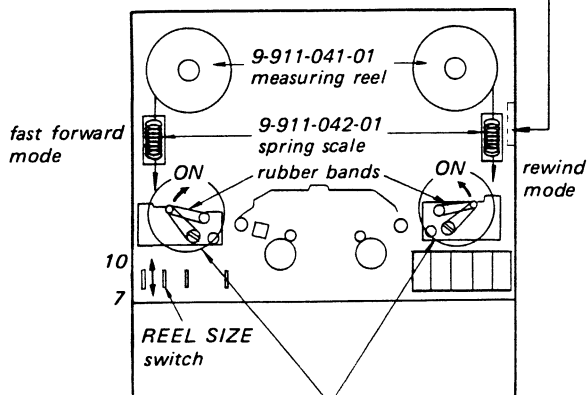
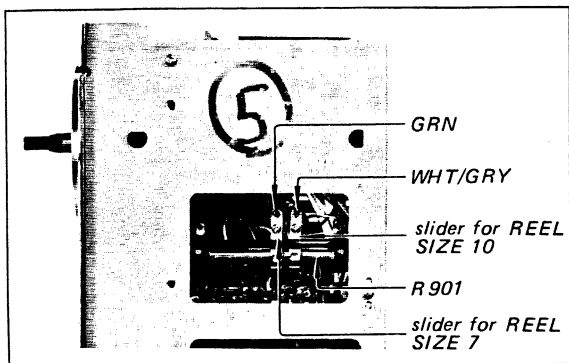

Fasten the tension arms with rubber bands to operate the unit.

10. Playback Take-up Torque Adjustment

1. Supply the rated power voltage.
2. Fasten the tension arms with rubber bands as shown, thus activating them.
3. Turn the TAPE SPEED switch to "19 cm 7½."
4. Place the unit in playback mode.
5. Pull the spring scale in the direction shown by the arrow and measure the take-up torque with REEL SIZE switch at "10" and "7". Torques should be as shown in the following table.

Specification:

REEL SIZE switch	Take-up Torque
10	580 to 620 g·cm (8.05 to 8.61 oz·inch)
7	280 to 320 g·cm (3.89 to 4.45 oz·inch)

If necessary, adjust the torque by moving the sliders of the adjustable resistor (R902).

— Left side —

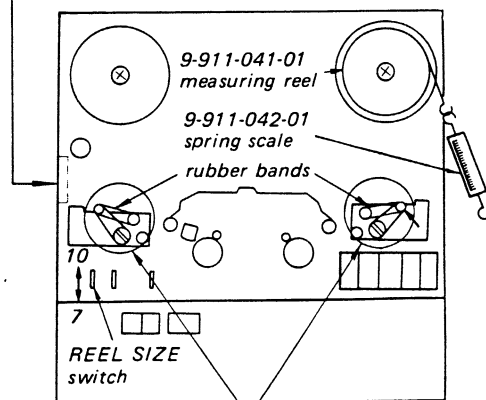
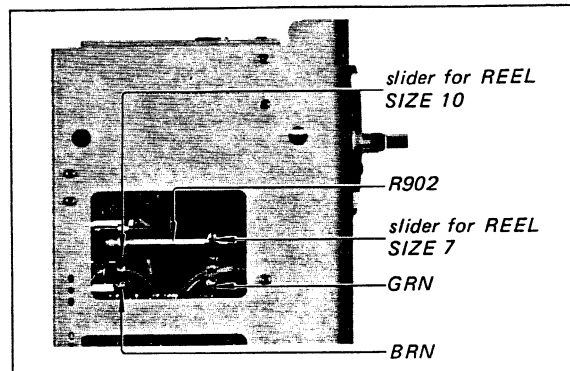

Fasten the tension arms with rubber bands to operate the unit.

11. Head Rotation Solenoid (PM6) Adjustment
 – Stop Mode –

While pushing the pole piece into the solenoid to the end, specified clearance should exist.

If necessary, loosen the screws and adjust the solenoid position.

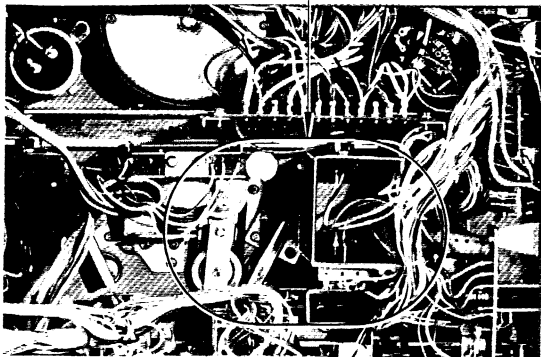
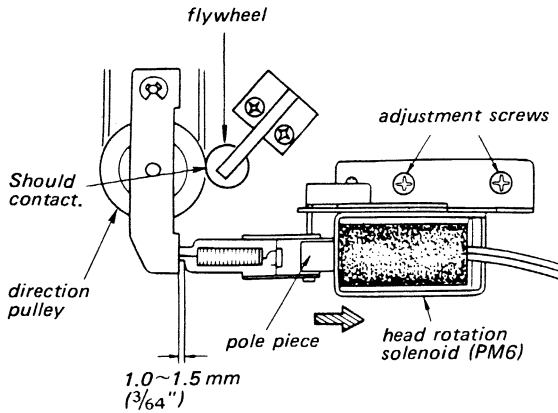

12. Small Gear (for head rotation) Adjustment
 – Forward Playback Mode –

Loosen the setscrew and adjust the clearance shown.

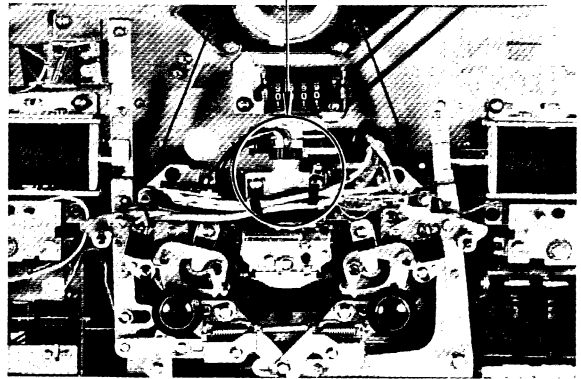
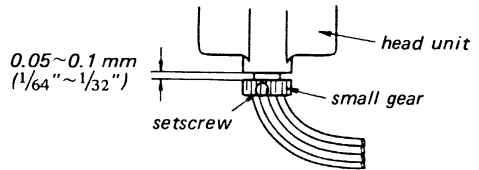

13. Reel Table Height Adjustment

After the adjustment, apply locking compound to the adjusted screws.

1. Thread the tape from a 180 mm (7 inches) plastic reel as shown.
2. Fasten the tension arms with rubber bands as shown.
3. Adjust the reel table height so that the tape travels in the center of both reel flanges in fast forward and rewind modes.

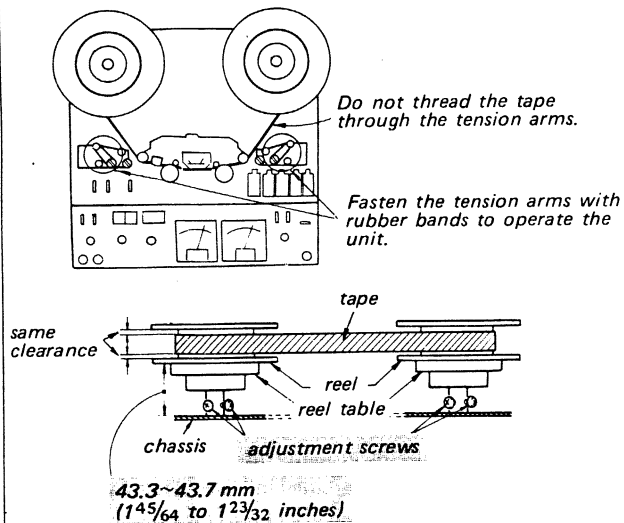

4. Tape should not touch the flanges of both reels in both forward and reverse playback modes.

14. Tape Guides Adjustment (1)

1. Thread the tape from a 180 mm (7 inches) plastic reel as shown.
2. Turn the two screws indicated by ★ counterclockwise until it stops, and then turn them clockwise $2\frac{1}{2}$ turns.
3. Turn the two screws indicated by ● so that the tape travels in the center of both reel flanges in rewind and fast forward modes.
4. Turn the two tape-guide screws indicated by ▲ for fine adjustment, so that the tape travels in the center of the guides without tape curl in forward playback mode.
5. When the tape curls, repeat the above steps.
6. After adjustment, lock the screws indicated by ● with locking compound.

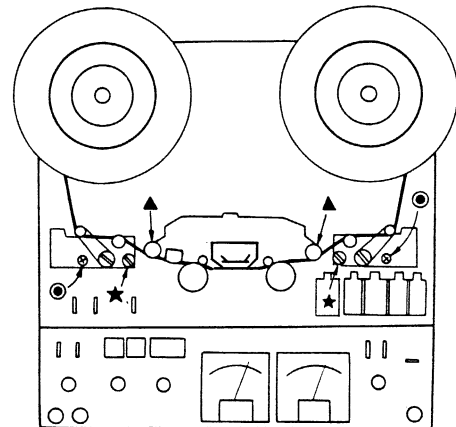

15. Tape Guide Adjustment (2)

Perform this adjustment after the reel table height adjustment and the tape guides adjustment (1) are completed.

If necessary, adjust the tape guides A through F as shown below to eliminate tape curls.

- Note:** 1. Tape guide adjustment should be made with reference to the horizontal center line of the record and playback heads of the rotary head unit.
2. When the rotary head unit is rotated for normal and reverse modes, outer edges of first tracks of record and playback heads should be 0.025 mm (1 mil) inside the tape edges.

1. In forward and reverse playback modes, tape should not curl at all the tape guides A through F.

Note: Tape guides B, C, D and E are tapered. So the tape is pressed downwards at tape guides B and C, and is pressed upwards at tape guides D and E.

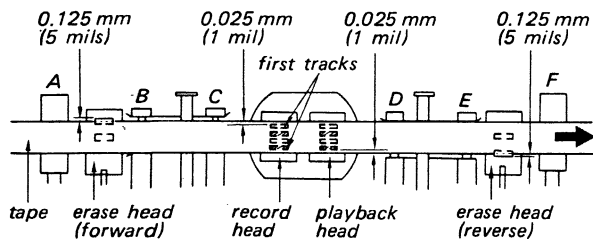

Note: Head cores shown by are those for reverse mode.

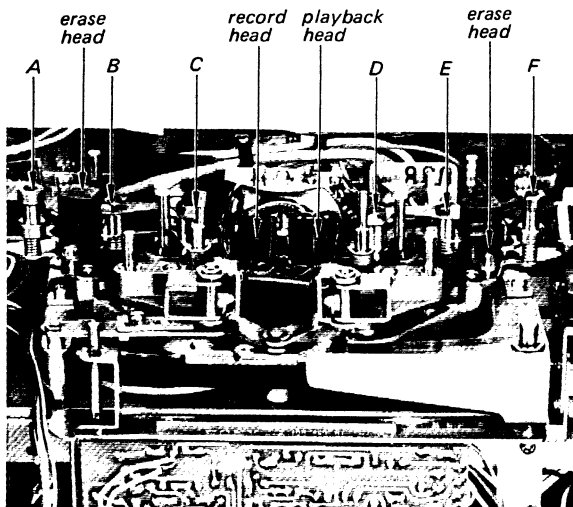

2. When the tape curls, adjust the tape guides A, B, E and F with tape guides C and D as standards. Do not adjust tape guides C and D, otherwise the head height adjustment should be made again.

Tape Guide	Adjust Screw
A, F	within one turn
B, E	within ¼ turn

3. When the tape curls at tape guide A or F, eliminate curl by moving the tape guide A or F to the curled-tape side.

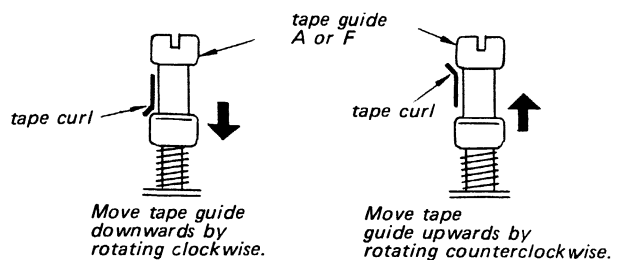

4. When the tape curls at tape guide B or E, eliminate curl by moving the tape guide B or C to the curled-tape side in the same manner as shown in 3 above.
5. When the tape curls at tape guide C or D, adjust the position of tape guide B or E as shown in 4. above and eliminate curl at tape guide C or D. If the tape curls at the tape guide B or E at this step, eliminate the curl by adjusting the position of the tape guide A or F.

6. After above adjustments, check for the following with SONY super 150 tape threaded.
- (1) Operate the unit in forward playback mode. Top edges of the first tracks of record and playback heads should be 0.025 mm (1 mil) inside the top edge of the tape, and the top edge of the first track of the forward erase head (left side) should expose 0.125 mm (5 mils) above the top edge of the tape. If not, proceed to step 8.

- (2) Operate the unit in reverse playback mode. Bottom edge of the first tracks of record and playback heads should be 0.025 mm (1 mil) inside of the bottom edge of the tape, and the bottom edge of the first track of the reverse erase head (right side) should expose 0.125 mm (5 mils) below the bottom edge of the tape.

If not, proceed to step 7.

7. When Step 6. (2) is not satisfied:

- (1) Center line of the record and playback head is displaced ($A/2 + 0.025$) mm upwards in forward playback mode and the tape guides are adjusted for this head position.
- (2) Move the tape guides C and D downwards by $A/2$ mm by turning them clockwise. Next turn the zenith adjustment screws of the record head counterclockwise so that the bottom edge of the first track of the record head enters 0.1 ~ 0.2 mm (6 mils) from the bottom edge of the tape. Then turn the setscrews clockwise to obtain the specified value, i.e., 0.025 mm (1 mil).
- (3) Change the mode to forward playback and adjust the setscrews of the playback head to obtain the specified value, i.e., 0.025 mm (1 mil).

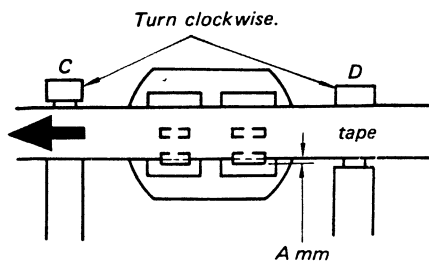
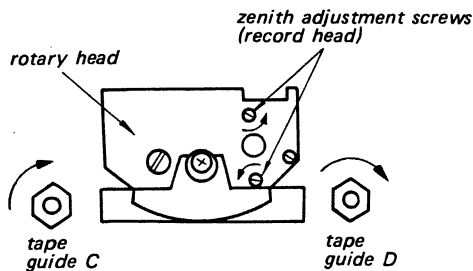

8. When Step 6. (1) is not satisfied:

- (1) Center line of the record and playback head is displaced ($A/2 + 0.025$) mm downwards in reverse playback mode and the tape guides are adjusted for this head position.
- (2) Move the tape guides C and D upwards by $A/2$ mm by turning them counterclockwise. Next turn the setscrews of the playback head clockwise until the top edge of the first track of the playback head becomes flush with the top edge of the tape. Then further turn the setscrews by 18 degrees.
- (3) Change the mode to reverse playback and adjust the setscrews of the record head to obtain the specified value, i.e., 0.025 mm (1 mil).

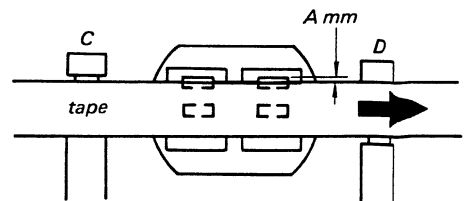
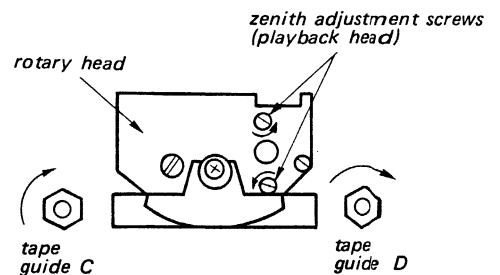

9. When the top edges of the first tracks of the record and playback head cores expose outside, the tape in both forward and reverse playback modes, or the cores place inside the tape in both forward and reverse playback heads, tape guides are adjusted correctly and the head height adjustment remains.
10. When the top edges of the first tracks of the record and playback head cores expose the top edge of the tape in forward playback mode and enter too much in reverse playback mode, or vice versa, head heights are adjusted correctly and perform the tape guide adjustment.
11. When Steps 7, 8, 9 or 10 is performed, readjust tape curl adjustment and tension arm height adjustment.

12. Erase Head Zenith and Azimuth Adjustment
Perform this adjustment when the specified height of both forward and reverse erase heads is not obtained.

lly
*

- (1) Turn the zenith adjustment setscrews in the same direction and same amount to obtain the specified spacing between the top edge of the forward erase head core and the top edge of the tape, and between the bottom edge of the reverse erase head core and the bottom edge of the tape, i.e., 0.125 mm (5 mils).

Note: When the zenith adjustment setscrew is turned by 90 degrees, head height can be varied by 0.125 mm (5 mils).

- (2) Turn the azimuth adjustment screw to make the top or bottom edge of the head core parallel with the top or bottom edge of the tape.

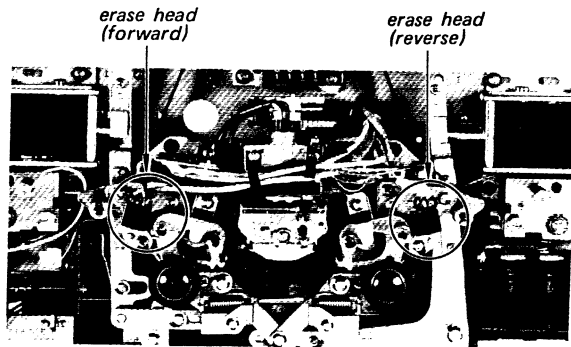
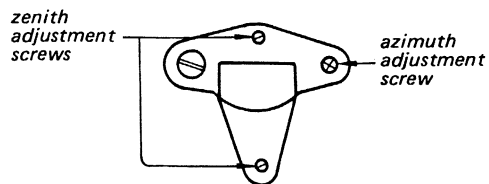

13. Lock the adjusted screws except for those of the record and playback heads with locking compound. Use transparent locking compound for tape guides A and F.

16. Tape Shifter Position Check

Perform this check for both left and right shifters with the unit in horizontal position.

1. In playback mode the shift levers should not touch the head deck.

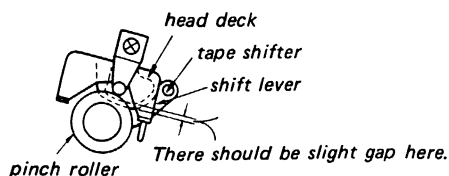

2. With the Super 150 tape threaded and in playback mode, the tape shifters should not touch the tape.
3. When the mode is changed from playback or stop to fast forward and/or rewind at tape end, the tape shifters should release the tape from the record and playback heads.
4. Tape shifters should have some play when they are moved with fingers. In rewind and fast forward modes, there should be more than 2 mm ($\frac{3}{32}$ inch) gap between the tape and the record and playback heads. At this time the tape may touch the erase head.

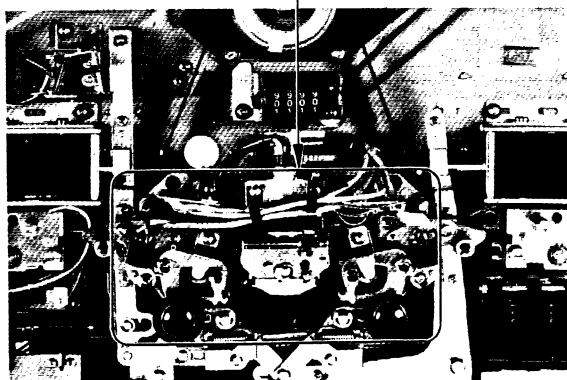
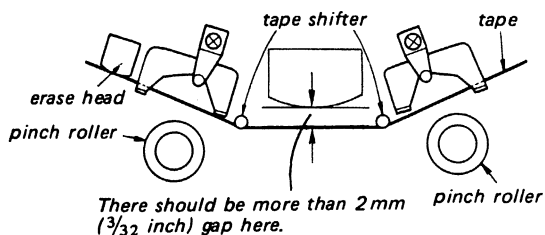

17. Function Switch Operation Check

1. Push the POWER switch ON with the tension arms released. Next push each function button. No operation should take place, and each function button should not lock.
2. When the tension arm L and/or R are activated, the stop solenoid should be de-energized. The solenoid can be seen when looked at in the direction of the arrow indicated by ★. When the solenoid is de-energized, a click can be heard.
3. Activate the tension arm L or R, and make sure of the following functions.
 - 3-1. Push the forward button. The button should lock. When the activated tension arm is released, the locked button should release itself.
 - 3-2. Push the forward button. Then push the stop button. At this time, the locked forward button should release itself.
 - 3-3. Push the forward button. Then push the POWER switch OFF. The locked forward button should remain locked. Next push the POWER switch ON. The forward button should still remain locked.
 - 3-4. Push the fast forward button. The button should lock. When the activated tension arm is released, the locked button should release itself.
 - 3-5. Push the fast forward button. Then push the stop button. At this time the locked button should release itself.
 - 3-6. Push the rewind button. The button should lock. When the activated tension arm is released, the locked button should release itself.
 - 3-7. Push the rewind button. Then push the stop button. At this time the locked button should release itself.

- 3-8. Push the reverse button. The button should lock. When the activated tension arm is released, the locked button should release itself.
- 3-9. Push the reverse button. Then push the stop button. At this time, the locked reverse button should release itself.
- 3-10. Push the reverse button. Then push the POWER switch OFF. The locked reverse button should remain locked. Next push the POWER switch ON. The reverse button should still remain locked.

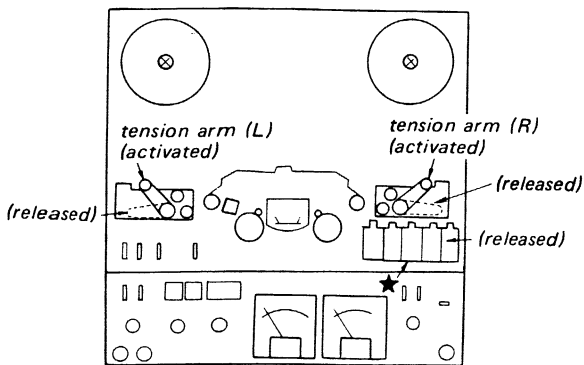

18. Tension Regulator Adjustment (Not normally performed) – Forward and Reverse Playback Modes –

Note: For this adjustment a super low frequency oscillator (3 Hz to 10 Hz) is required. Without the oscillator, do not perform this adjustment and only replace the defective parts. When adjusting adjustable resistors, turn them in the direction of increasing torque, so that the torque rises to the specified value.

- 1. Supply the rated power voltage.
- 2. Unsolder the three lead wires of the FG (frequency generator) coil in the supply reel motor M1, connect a super low frequency oscillator of -20 dB output across R701 (3.9 k) through a 100 μ F electrolytic capacitor.

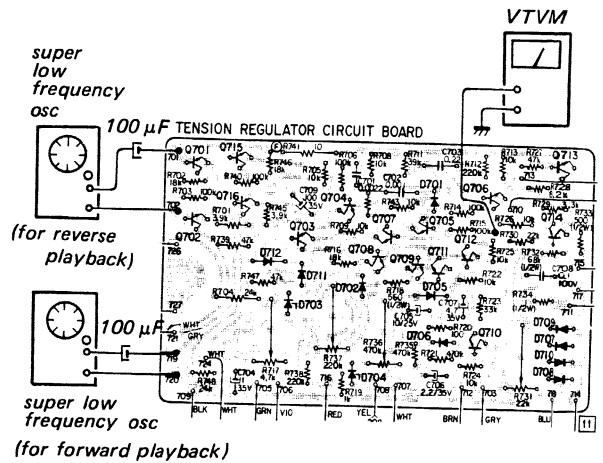

- 3. Set TAPE SPEED switch to "9.5 cm 3 $\frac{3}{4}$ " and REEL SIZE switch to "10".
- 4. Put the torque meter on the supply reel table and thread the tape as shown below.

– Forward Playback –

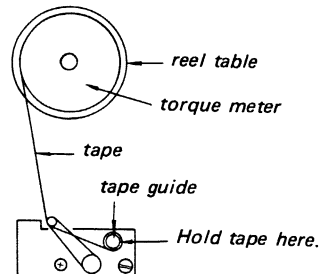

- 5. Adjust the oscillator frequency so that the voltage between the emitter of Q712 transistor and the chassis ground is 9 volts in playback mode.

6. With the frequency adjusted in step 5, adjust R731 so that the supply motor torque is 250 g-cm (3.47 oz · inch).
7. Change the oscillator frequency to 10 Hz and adjust R717 so that the torque is 80 g-cm (1.11 oz · inch).
8. Change the oscillator frequency to 3.3 Hz and adjust R736 so that the torque is 310 g-cm (4.30 oz · inch).
9. Repeat steps 6 and 7 once more.
10. Set TAPE SPEED switch to "19 cm 7½" and change the oscillator frequency to 6.6 Hz. Then adjust R737 so that the torque is 310 g-cm (4.30 oz · inch).
11. In the same manner, check for the torques in reverse playback mode.

— Reverse Playback —

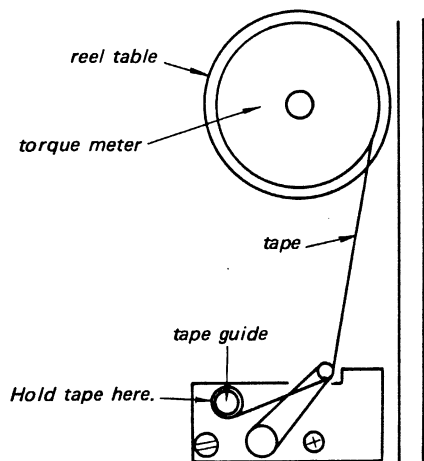

Specification:

TAPE SPEED switch	Oscillator frequency	Torque
9.5 cm 3¾	As obtained in step 5.	238~262 g-cm (3.30~3.63 oz-inch)
	10 Hz	76~84 g-cm (1.06~1.17 oz-inch)
	3.3 Hz	295~325 g-cm (4.10~4.41 oz-inch)
19 cm 7½	6.6 Hz	295~325 g-cm (4.10~4.41 oz-inch)

When above torques are not obtained, repeat steps 2 through 10.

19. Tape Operation Check

1. Thread the SONY super 150 tape.
2. Press the forward button. The tape should run at the rated speed and in the forward direction.
3. Press the fast forward button and the unit should immediately change its mode to fast forward.
4. Press the forward button. Now the tape should stop running once and then the unit should become in the forward mode.
5. Press the rewind (or reverse fast forward) button and the unit should normally operate in rewind mode.
6. Press the forward button. Now the tape should stop running once and then the unit should become in the forward mode.
7. At the tape start, set the unit to the forward mode. Set the PAUSE switch to ON (lamp will light) and the tape should stop running. Next set the PAUSE switch to OFF, and the tape should start running again.
8. At the tape end, set the unit to the reverse mode. Set the PAUSE switch to ON (lamp will light) and the tape should stop running. Next set the PAUSE switch to OFF, and the tape should start running again.
9. Change the tape and reel to other ones. The tape should not make any slacks when the mode is changed from forward, fast forward, reverse or rewind to stop mode.

20. Record Mechanism Operation Check

1. Set a 7" or 10" full reel and an empty reel on the unit and thread the tape.
2. RECORD buttons should not lock when only either of them is pressed.
3. REC TIMER LOCK knob should not lock when only the knob is pushed to the right.
4. Push the REC TIMER LOCK knob to the right while pressing the RECORD button (or buttons). Now the RECORD button (or buttons) and REC TIMER LOCK knob should firmly lock. The REC TIMER LOCK knob should not release when it is forcibly pushed to the left.
5. Turn the unit on. Press any one of the fast forward, reverse, rewind and stop buttons, and the locked RECORD button (or buttons) and REC TIMER LOCK knob should release.
6. Press the RECORD button (or buttons) and then the forward or reverse button. Now the record direction lamp should light and the unit should be in the record mode.
7. Timer-activated recording:
 - 1) Press the forward button. The unit should operate in the forward mode.
 - 2) Press the stop button.
 - 3) Pressing the RECORD button (or buttons), push the REC TIMER LOCK knob to the right. Now only the right side record direction lamp should light.
 - 4) Turn the unit off. The forward button should keep locked.
 - 5) Turn the unit on. The unit should operate in the forward record mode.
 - 6) Turn the unit off and press the reverse button and lock.
 - 7) Turn the unit on. The unit should be in the forward record mode.
 - 8) Turn the unit off and then on. The unit should operate in the forward record mode.
 - 9) Repeat above steps 1) through 8) five times. The unit should correctly operate without fail.
 - 10) Press the reverse button. The rotary head should rotate and the unit should operate in the reverse mode.
 - 11) Press the stop button.

- 12) Pressing the RECORD button (or buttons), push the REC TIMER LOCK knob to the left. Now the left side record direction lamp should light.
- 13) Turn the unit off. The reverse button should keep locked.
- 14) Turn the unit on. The unit should operate in the reverse record mode.
- 15) Turn the unit off. Press the forward button and lock.
- 16) Turn the unit on. The unit should operate in the reverse record mode.
- 17) Turn the unit off and then on. The unit should operate in the reverse record mode.
- 18) Repeat above steps 10) through 17) five times. The unit should correctly operate without fail.

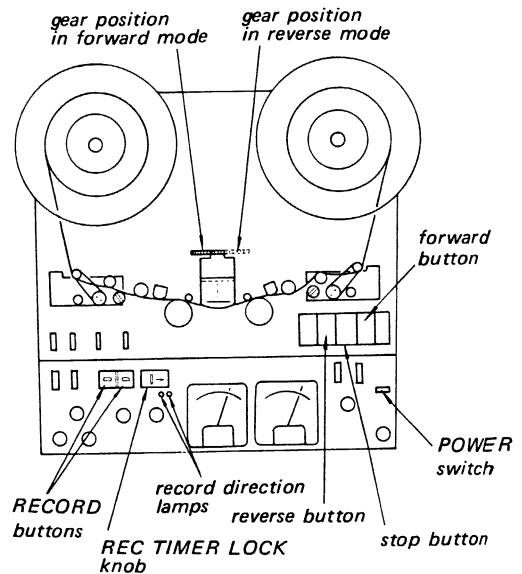

8. Set the unit in the forward record mode. Press the reverse button. Now the RECORD button (or buttons) should release and the unit should operate in the reverse playback mode.
9. Set the unit in the reverse record mode. Press the forward button. Now the RECORD button (or buttons) should release and the unit should operate in the forward playback mode.
10. Set the unit in the forward record mode. Set the AUTO REV switch to REV or CONT REV. The RECORD button (or buttons) should not release until the tape travels one round, supposed that the sensing foil is attached to the tape (REV mode), or the stop button is pressed (CONT REV mode).

21. Automatic Reverse Operation Check

1. Thread the tape on the unit.
2. Attach two sensing foils of 13 mm (1/2") long on the tape and one meter (3.3 ft.) apart.
3. Set the AUTO REV switch to NON REV and press the forward button. The set should not change the tape travelling direction when the sensing foil contacts both the sensing poles, and when the reverse button is pressed.
4. Set the reels so that the sensing foils place in each reel.
5. Set the AUTO REV switch to REV and press the forward button. When the left-side sensing foil contacts the left-side sensing pole, the unit should change the tape travelling direction. The unit should not change the tape travelling direction when the right-side sensing foil contacts the right-side sensing pole. When the reverse button is pressed, the unit should not change the tape travelling direction when the sensing foil contacts both the sensing poles.
6. Set the reels so that the sensing foils place in each reel. Set the AUTO REV switch to CONT REV and press the forward button. The unit should change the tape travelling directions when the left-side sensing foil contacts the left-side sensing pole and when the right-side sensing pole and when the right-side sensing foil contacts the right-side sensing pole.

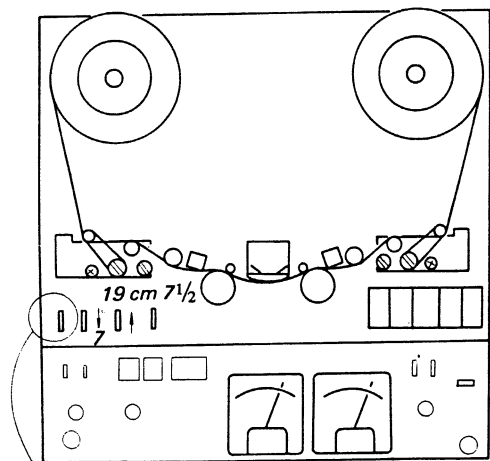

AUTO REV switch



3-2. ELECTRICAL ADJUSTMENTS

Precaution:

- Clean the following parts with a swab moistened with alcohol:

record head	pinch rollers
playback head	rubber belts
erase heads	idlers
capstans	tape guides
- Demagnetize record, playback and erase heads with a head demagnetizer.
- Do not use magnetized screwdriver for adjustments.
- After adjustments, apply locking compounds to the adjusted parts.
- Adjustments should be performed in the order listed in this service manual.
- Adjustments and measurements should be performed for each L and R channel with the rated power supply voltage unless otherwise specified.
- Switches and controls, which are not given in "Settings" for the each adjustment, can be set in any modes or positions. POWER switch, however, should be ON unless otherwise noted.

Test Equipment/Tools Required:

audio oscillator (af osc)
 VTVM
 VOM
 attenuator (600Ω)
 digital frequency counter or speed checker (SONY LFM-30)
 oscilloscope
 resistors: 600 Ω, 10 kΩ, 100 kΩ
 SONY test tape
 J-19-F2

Tone:	1	2	3	4	5	6	7
Frequency: (Hz)	400	400	10 k	12.5 k	7 k	80	40
Level (dB):	0	-10	-10	-10	-10	-10	-10

J-19-A2 (12.5 kHz, -10 dB)
 SPC-47 (4 kHz, 0 dB)
 blank tapes (completely erased)
 NPS-1 (for NORMAL record)
 SLH-S1 (for SPECIAL record)

Normal Input Level

	Impedance	Level
MIC	300 Ω	-60 dB (0.77 mV)
LINE IN	10 kΩ	-10 dB (0.25V)
REC/PB		

Normal Output Level

	Load Impedance	Level
LINE OUT	100 kΩ	-5 dB (0.44 V)
HEADPHONES	8 Ω	-28 dB (31 mV)
REC/PB		

1. B + 27V Adjustment

Settings:

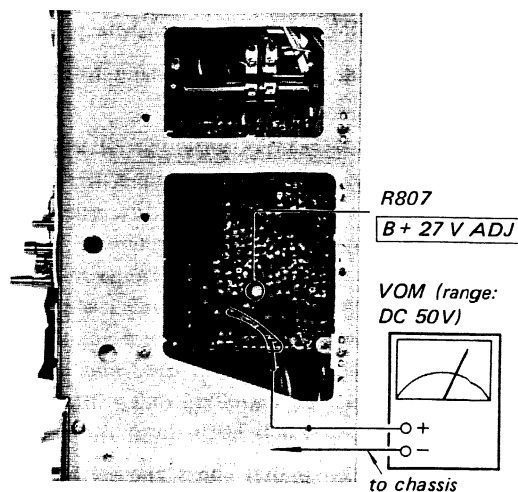

Procedure:

Adjust R814 for 26.5 to 27.0 V DC on VOM.

Note: The ripple voltage should be less than 1 mV p-p.

2. Tape Speed Adjustment

Settings:

- REEL SIZE switch: 7
- TAPE SPEED switch: 19 cm 7½ and 9.5 cm 3¾
- EQ (TAPE SELECT) switch: NORMAL
- MONITOR switch: TAPE
- PB LEVEL control: mechanical mid

Procedure:

Mode: playback

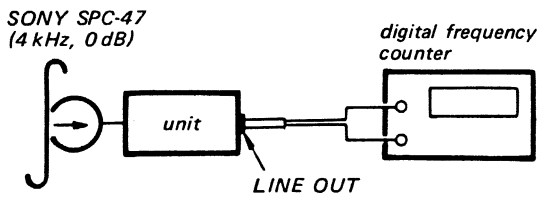
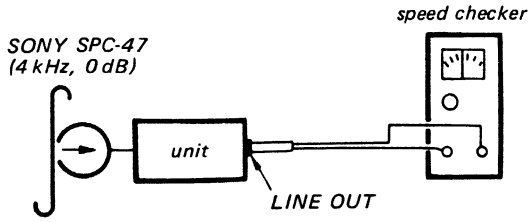

TAPE SPEED	Adjust	Specification	
		speed checker	digital frequency counter
19 cm 7½	R616	-1 ~ +1%	3,960 ~ 4,040 Hz
9.5 cm 3¾	R618	-1.5 ~ +1.5%	1,970 ~ 2,030 Hz

Adjustment Location:

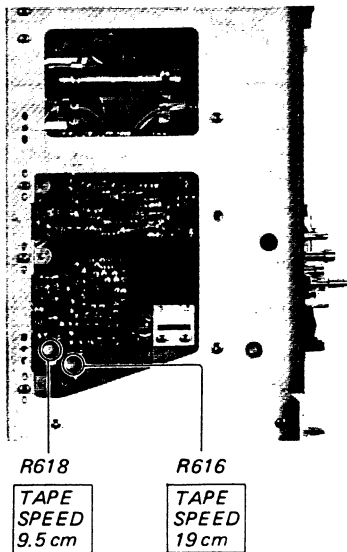

3. Meter Level Adjustment

Settings:

- EQ (TAPE SELECT) switch: NORMAL
- MONITOR switch: SOURCE
- PB LEVEL control: mechanical mid

Procedure:

1. Calibrate the level meters for 0% indication with POWER switch OFF.
2. Adjust LINE IN control for -5 dB (0.44 V) VTVM reading.

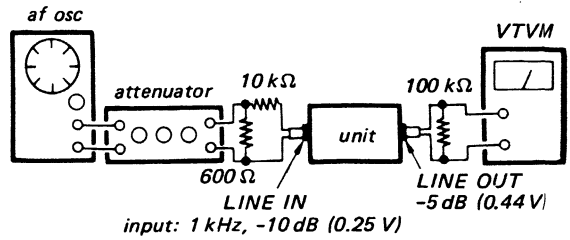

3.

Adjust	Remarks
R336 (L channel)	0 VU on the level meters
R436 (R channel)	

Adjustment Location:

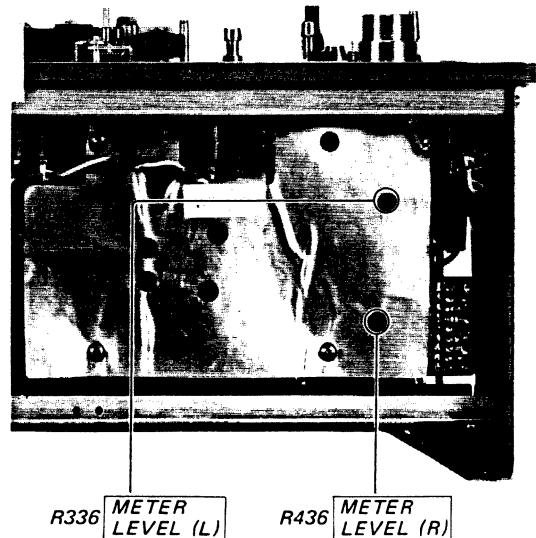

4. Playback Head Angle Adjustment

Settings:

- REEL SIZE switch: 7
- TAPE SPEED switch: 19 cm 7½
- EQ (TAPE SELECT) switch: NORMAL
- MONITOR switch: TAPE
- PB LEVEL control: mechanical mid

Procedure:

1. Mode: forward playback

SONY J-19-F2
(3rd tone, 10 kHz, -10 dB)

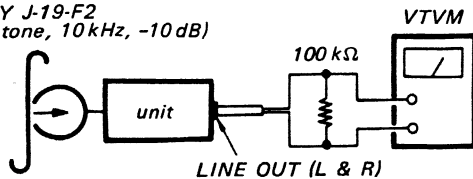

Loosen the adjustment screws and correctly position the playback head for the highest VTVM reading.

Note: Slightly touch the supply reel and at this time the VTVM reading deviation should be less than 1 dB.

2. Change the mode to reverse playback and check for the same VTVM reading.

Adjustment Location:

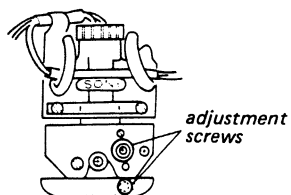
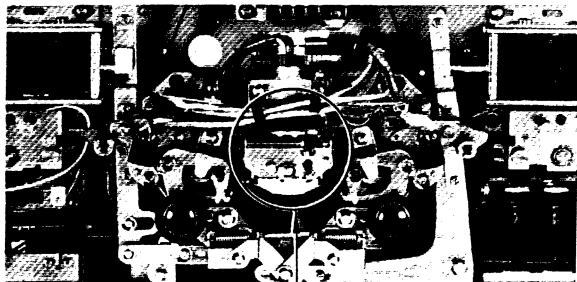

5. Playback Head Azimuth and Phase Adjustments

Settings:

- REEL SIZE switch: 7
- TAPE SPEED switch: 19 cm 7½
- EQ (TAPE SELECT) switch: NORMAL
- MONITOR switch: TAPE
- PB LEVEL control: mechanical mid

Procedure:

If an oscilloscope is available, employ Procedure 2. If a simplified test is to be made, follow Procedure 1.

1. Mode: forward playback

SONY J-19-A2
(12.5 kHz, -10 dB)

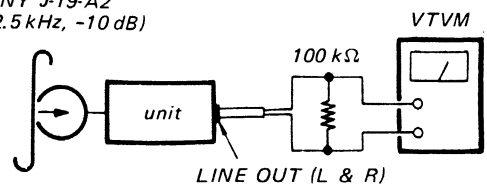

Turn the adjustment screw shown in the photo below for the highest VTVM reading. If the highest peaks for L and R do not coincide, place the adjustment screw to the mechanical mid of the two positions for the peaks.

2. Mode: forward playback

SONY J-19-A2
(12.5 kHz, -10 dB)

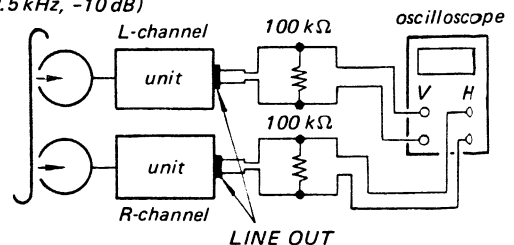

Adjust	On the oscilloscope			
azimuth adjustment screw				
	in-phase	30°	90°	more than 90°
	good			wrong

3. Mode: reverse playback
Perform the same procedure in reverse playback mode.

Adjustment Location:

Forward playback mode:

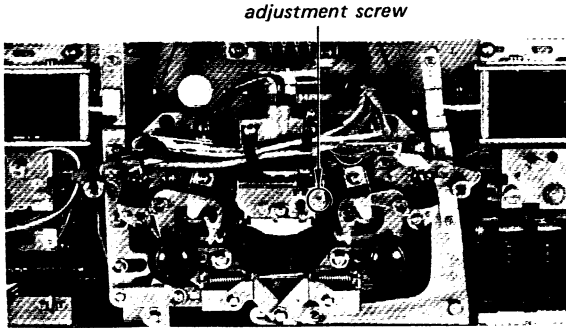

Reverse playback mode.

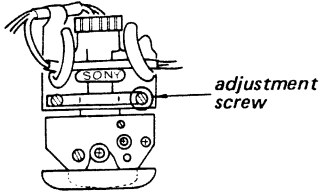

6. Playback Equalizer Adjustment

Settings:

- REEL SIZE switch: 7
- TAPE SPEED switch: 19 cm 7½
- EQ (TAPE SELECT) switch: NORMAL
- MONITOR switch: TAPE
- PB LEVEL control: mechanical mid

Procedure:

Mode: forward playback

SONY J-19-F2
 (2nd tone, 400 Hz, -10 dB)
 (3rd tone, 10 kHz, -10 dB)

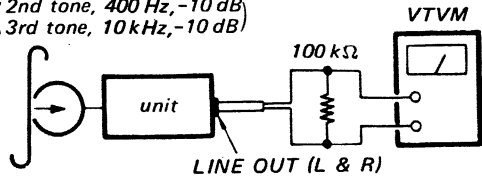

	Adjust	VTVM reading
2nd tone 400 Hz	PB LEVEL control	0 dB (0.775 V)
3rd tone 10 kHz	R311 (L channel) R411 (R channel)	0 dB (0.775 V)

Specification for the convenience of the more detailed test:

J-19-F2 (TAPE SPEED: 19 cm 7½)	
400 Hz	0 dB (reference)
10 kHz	0 ± 1 dB
12.5 kHz	-0.5 ± 1.5 dB
7 kHz	-0.5 ± 1.5 dB
80 Hz	+2 ± 2 dB
40 Hz	0 ± 2 dB

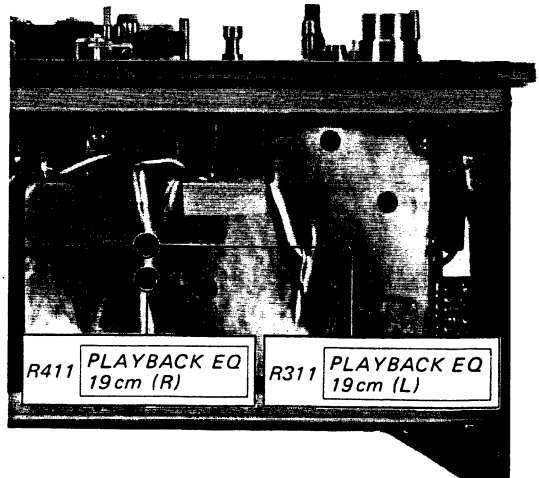

7. Playback Level Adjustment

Settings:

- REEL SIZE switch: 7
- TAPE SPEED switch: 19 cm 7 1/2
- EQ (TAPE SELECT) switch: NORMAL
- MONITOR switch: TAPE
- PB LEVEL control: mechanical mid

Procedure:

Mode: forward playback

SONY J-19-F2
(1st tone, 400 Hz, 0 dB)

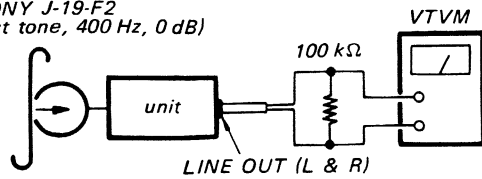

Adjust	VTVM reading
R317 (L channel)	-5 dB (0.44 V)
R417 (R channel)	allowance : ±1 dB

- Note:**
1. Turn the EQ (TAPE SELECT) switch to SPECIAL position and make sure that the output level rises by 2.5 ± 1 dB.
 2. Difference between L and R channels should be within 1 dB.

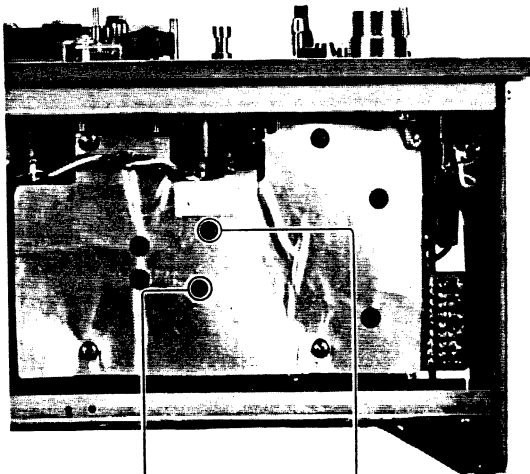

R417 PLAYBACK LEVEL (R)

R317 PLAYBACK LEVEL (L)

8. Record Head Angle Adjustment

Settings:

- REEL SIZE switch: 7
- TAPE SPEED switch: 19 cm 7 1/2
- BIAS (TAPE SELECT) switch: LOW
- EQ (TAPE SELECT) switch: SPECIAL
- MONITOR switch: TAPE
- LINE IN control: mechanical mid
- PB LEVEL control: mechanical mid

Procedure:

Mode: reverse record and simultaneous playback

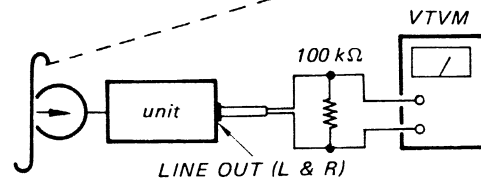
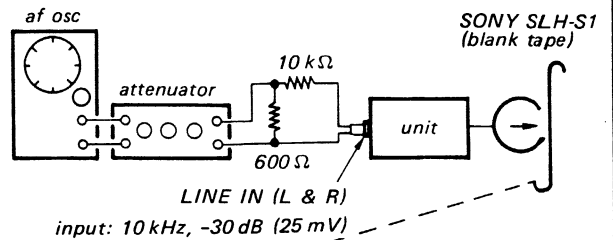

Loosen the adjustment screws and correctly position the record head for the highest VTVM reading.

Note: Slightly touch the supply reel and at this time the VTVM reading deviation should be less than 1 dB.

Adjustment Location:

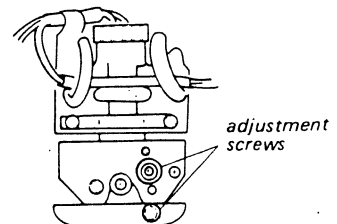
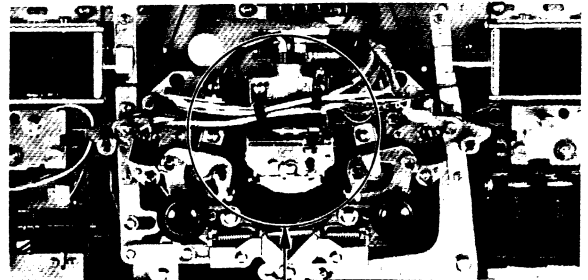

9. Record Head Azimuth and Phase Adjustments

Settings:

- REEL SIZE switch: 7
- TAPE SPEED switch: 19 cm 7 1/2
- BIAS switch: LOW
- TAPE SELECT (EQ) switch: SPECIAL
- MONITOR switch: TAPE
- LINE IN control: mechanical mid
- PB LEVEL control: mechanical mid

Procedure:

When an oscilloscope is available, employ Procedure 2. When a simplified test is made, follow Procedure 1.

1. Mode: reverse record and simultaneous playback

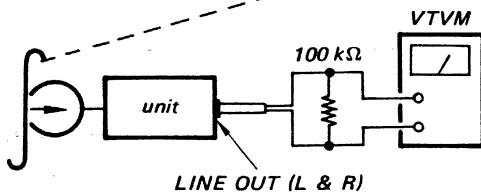
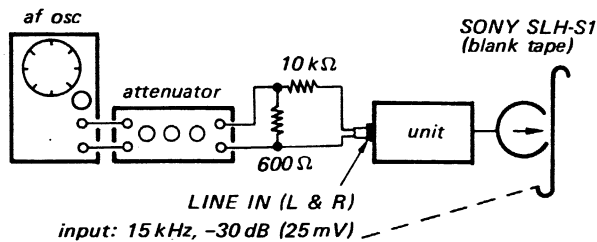

Turn the adjustment screw for the highest VTVM reading. If the highest peaks for L and R do not coincide, place the adjustment screw to the mechanical mid of the two positions for the peaks.

2. Mode: reverse record and simultaneous playback

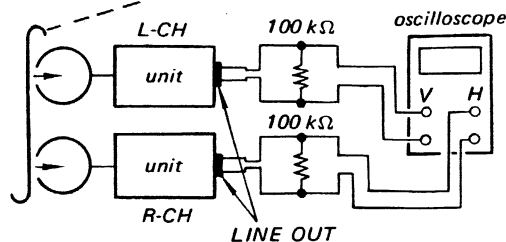
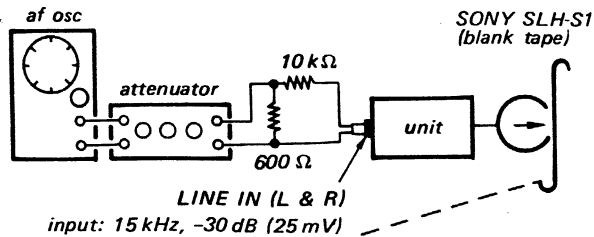

Adjust	On the oscilloscope			
azimuth adjustment screw				
	in-phase	30°	90°	more than 90°
	good			wrong

Note: Difference between the highest levels of L and R and the finally adjusted level should be within 1 dB.

Adjustment Location:

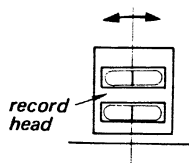
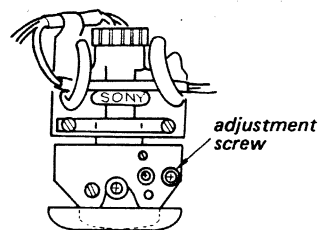

10. Bias Trap Adjustment

Settings:

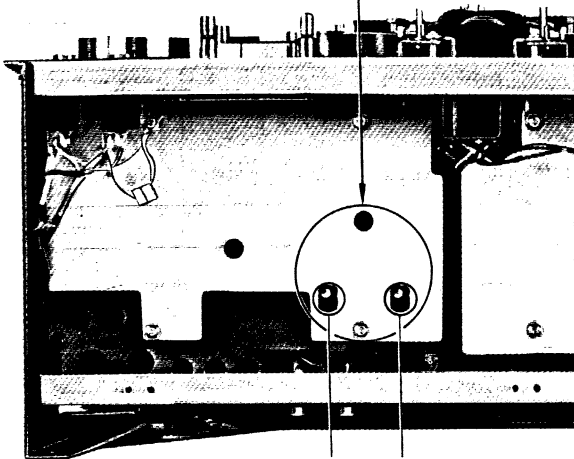
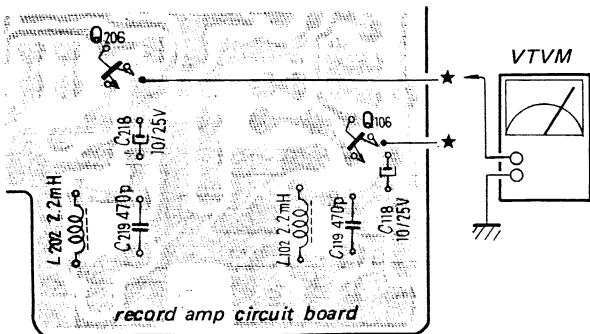
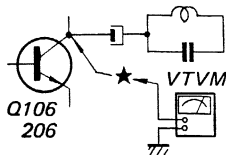

L202 (R) L102 (L)

Procedure:

In record mode turn L102 (L-channel) and L202 (R-channel) for the lowest VTVM reading (-40 dB (7.7 mV) or less).

11. Record Bias Adjustment

Settings:

- REEL SIZE switch: 7
- TAPE SPEED switch: 19 cm 7 1/2
- BIAS (TAPE SELECT) switch: LOW
- EQ (TAPE SELECT) switch: SPECIAL
- MONITOR switch: TAPE
- LINE IN control: mechanical mid
- PB LEVEL control: mechanical mid

Procedure:

Mode: forward record and simultaneous playback

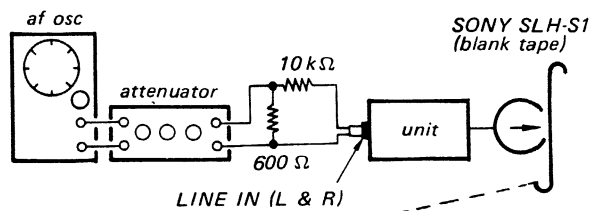

LINE IN (L & R)
input: 1 kHz, -10 dB (0.25 V)

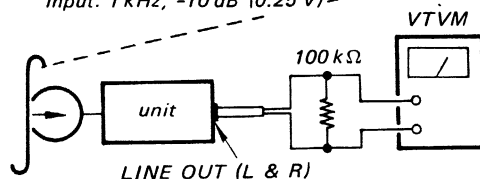

LINE OUT (L & R)

As trimmer capacitor C511 (L-channel) or C512 (R-channel) is slowly turned clockwise, VTVM reading will go up to a maximum and then start falling again. Adjust the capacitor until VTVM reads 0.5 dB below and beyond the maximum reading.

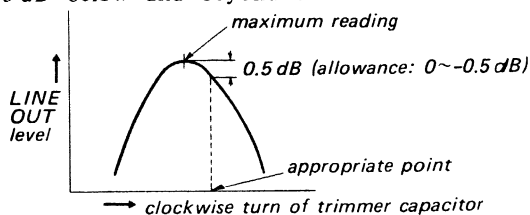

Adjustment Location:

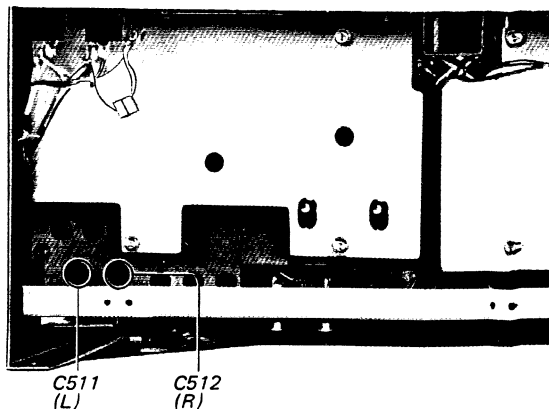

C511 (L) C512 (R)

12. Record Bias Frequency Adjustment

Settings:

REEL SIZE switch: 7
 TAPE SPEED switch: 19 cm 7½
 BIAS (TAPE SELECT) switch: LOW
 EQ (TAPE SELECT) switch: SPECIAL
 MONITOR switch: TAPE
 LINE IN control: mechanical mid
 PB LEVEL control: mechanical mid

Procedure:

1. Mode: forward stereo record

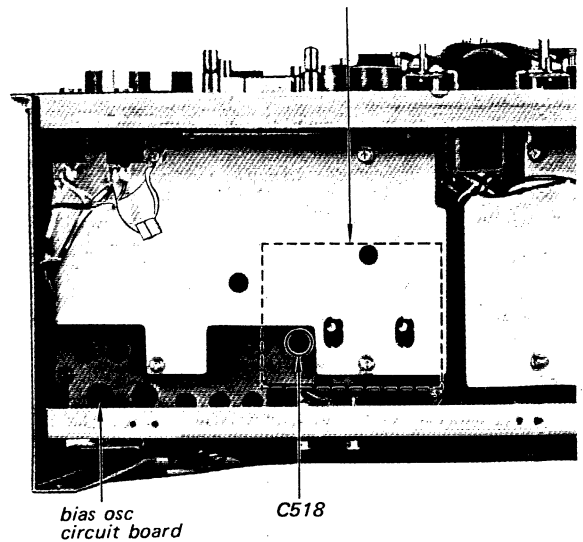
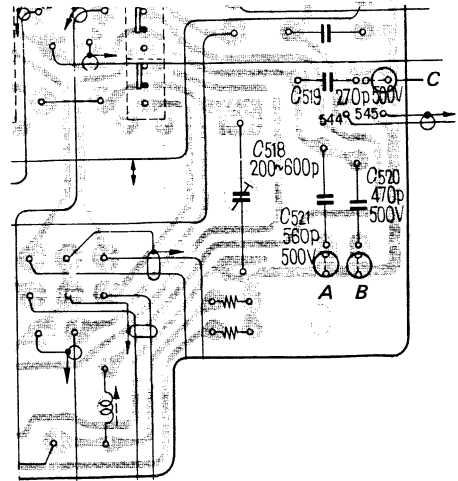
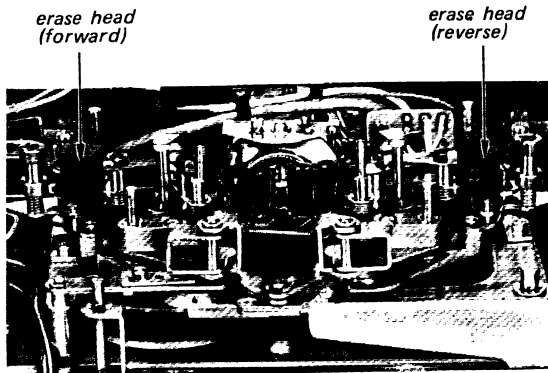
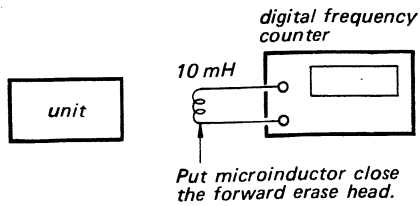

Adjust bias frequency by bridging the adjustment patterns at A, B or C on the bias osc circuit board to obtain 160 kHz frequency counter reading. Normally, patterns at B are bridged.

Specification: 145 kHz ~ 175 kHz

2. Mode: reverse stereo record

Put the microinductor close the reverse erase head and adjust C518 to obtain the same frequency as that obtained in Step 1 above.

Specification: ± 2 kHz of forward record bias frequency

13. Dummy Coil Adjustment

Settings:

- REEL SIZE switch: 7
- TAPE SPEED switch: 19 cm 7 $\frac{1}{2}$
- BIAS (TAPE SELECT) switch: LOW
- EQ (TAPE SELECT) switch: SPECIAL
- MONITOR switch: TAPE
- LINE IN control: mechanical mid
- PB LEVEL control: mechanical mid

Procedure:

1. Mode: Record and simultaneous playback.

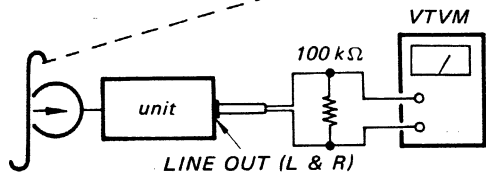
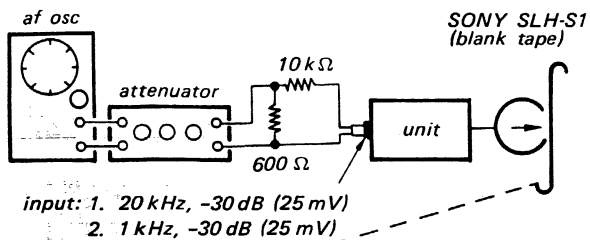

Adjustment Location:

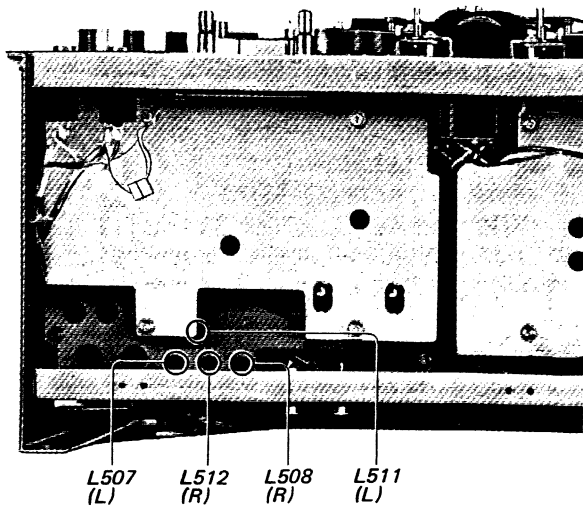

Step	Mode	Adjust	Remarks
1	stereo record and simultaneous playback	—	same VTVM reading allowance; 0 dB \pm 2 dB
2	L channel forward record and simultaneous playback	L508	
3	R channel forward record and simultaneous playback	L507	
4	L channel reverse record and simultaneous playback	L512	
5	R channel reverse record and simultaneous playback	L511	

20 kHz signal level when referred to 1 kHz signal: 0 dB \pm 3 dB

14. Record Level Adjustment

Settings:

- REEL SIZE switch: 7
- TAPE SPEED switch: 19 cm 7 1/2
- BIAS (TAPE SELECT) switch: LOW
- EQ (TAPE SELECT) switch: SPECIAL
- MONITOR switch: TAPE
- LINE IN control: mechanical mid
- PB LEVEL control: mechanical mid

Procedure:

Mode: forward record and simultaneous playback

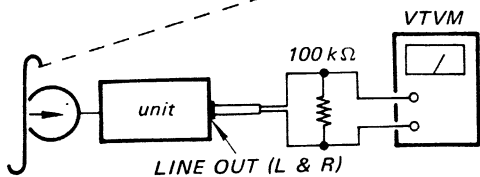
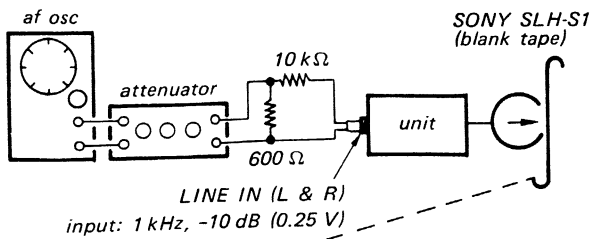

Adjust	VTVM reading
R125 (L channel)	-5 dB (0.44 V)
R225 (R channel)	

Adjustment Location:

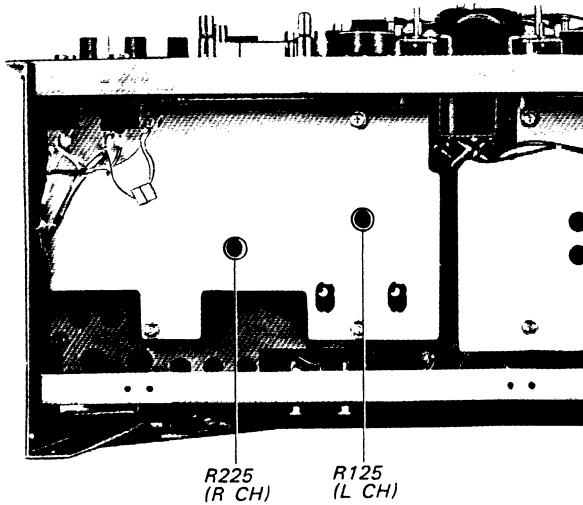

15. Overall Frequency Response (NORMAL RECORD EQ) Adjustment

Settings:

- REEL SIZE switch: 7
- TAPE SPEED switch: 19 cm 7 1/2
- BIAS (TAPE SELECT) switch: LOW
- EQ (TAPE SELECT) switch: NORMAL
- MONITOR switch: TAPE
- PB LEVEL control: mechanical mid

Procedure:

1. Mode: Record

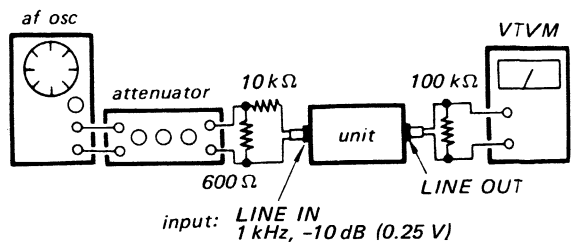

Set the LINE IN control to obtain the specified LINE OUT level.

2. Mode: forward record and simultaneous playback.

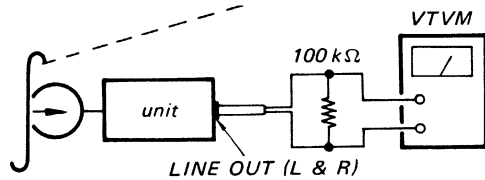
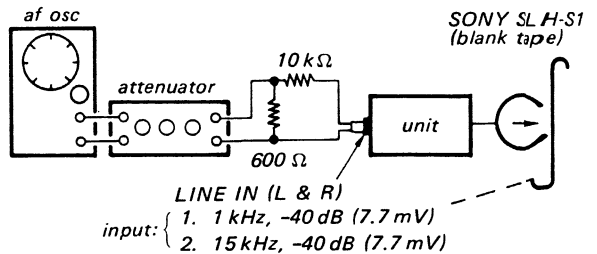

	Adjust	Remarks
1 kHz	L501 (L channel) and L502 (R channel)	Same LINE OUT level at both frequencies.
20 kHz		

Adjustment Location:

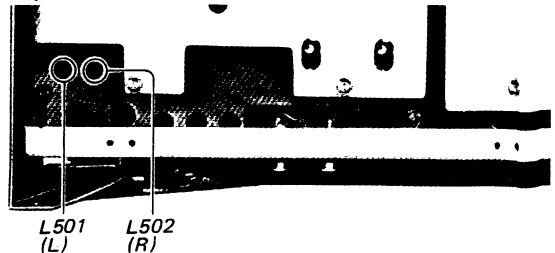

16. Overall Frequency Response (SPECIAL RECORD EQ) Adjustment

Settings:

- REEL SIZE switch: 7
- TAPE SPEED switch: 19 cm 7½
- BIAS (TAPE SELECT) switch: LOW
- EQ (TAPE SELECT) switch: SPECIAL
- MONITOR switch: TAPE
- PB LEVEL control: mechanical mid

Procedure:

1. Mode: forward record

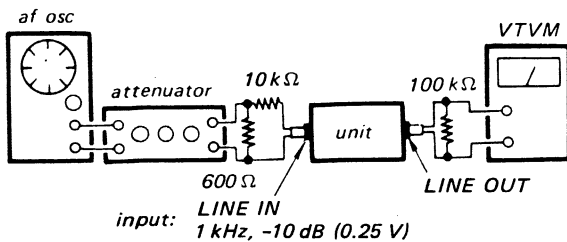

Set the LINE IN control to obtain the specified LINE OUT level.

2. Mode: forward record and simultaneous playback.

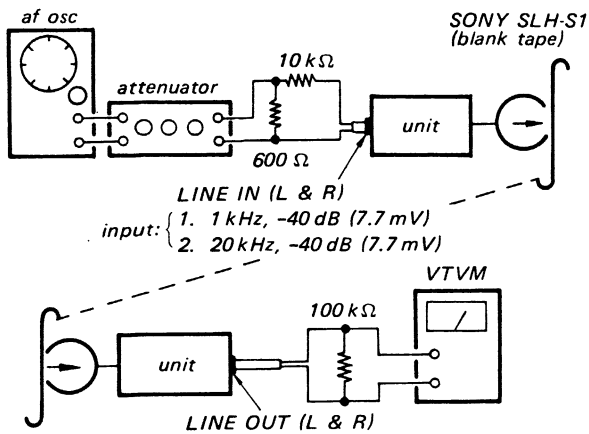

	Adjust	Remarks
1 kHz	L503 (L channel) and	Same LINE OUT level at both frequencies.
20 kHz	L504 (R channel)	

Adjustment Location:

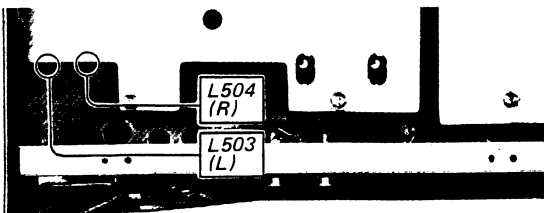

MEMO

Series of horizontal dotted lines for writing.

SECTION 4
DIAGRAMS

4-1. LEVEL DIAGRAMS

Playback Mode

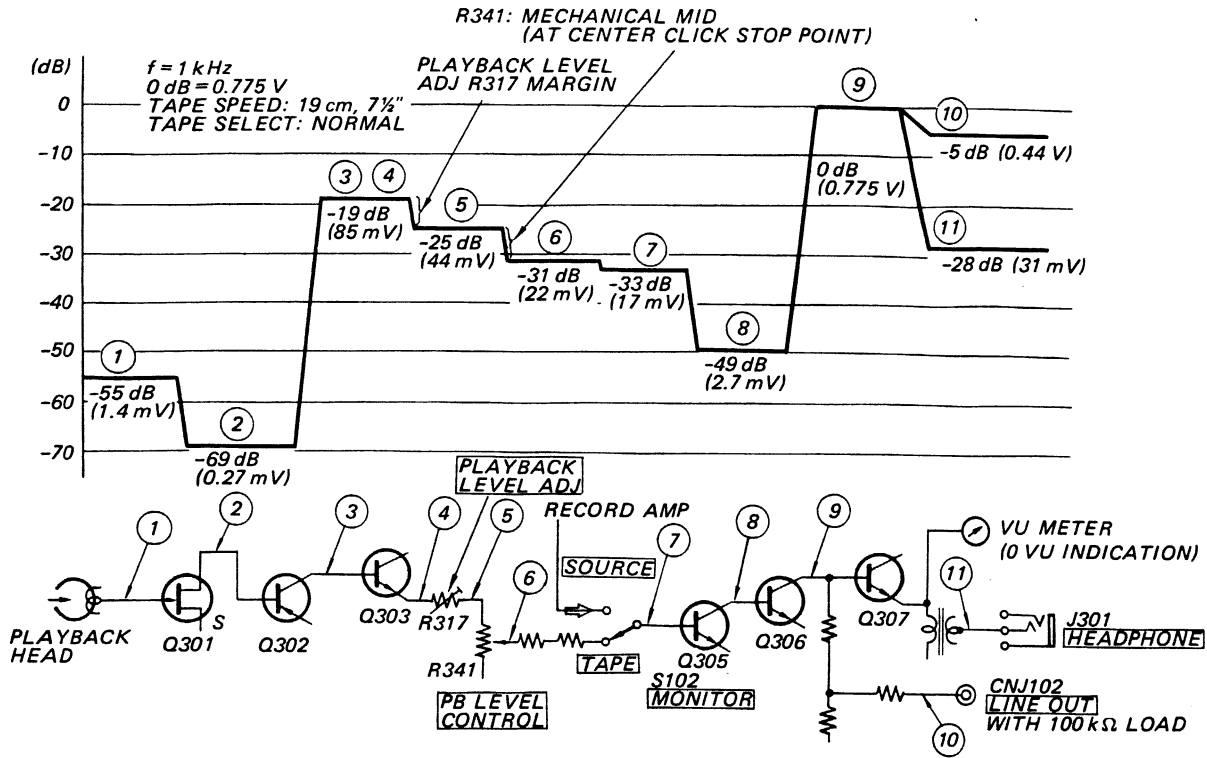

Record Mode

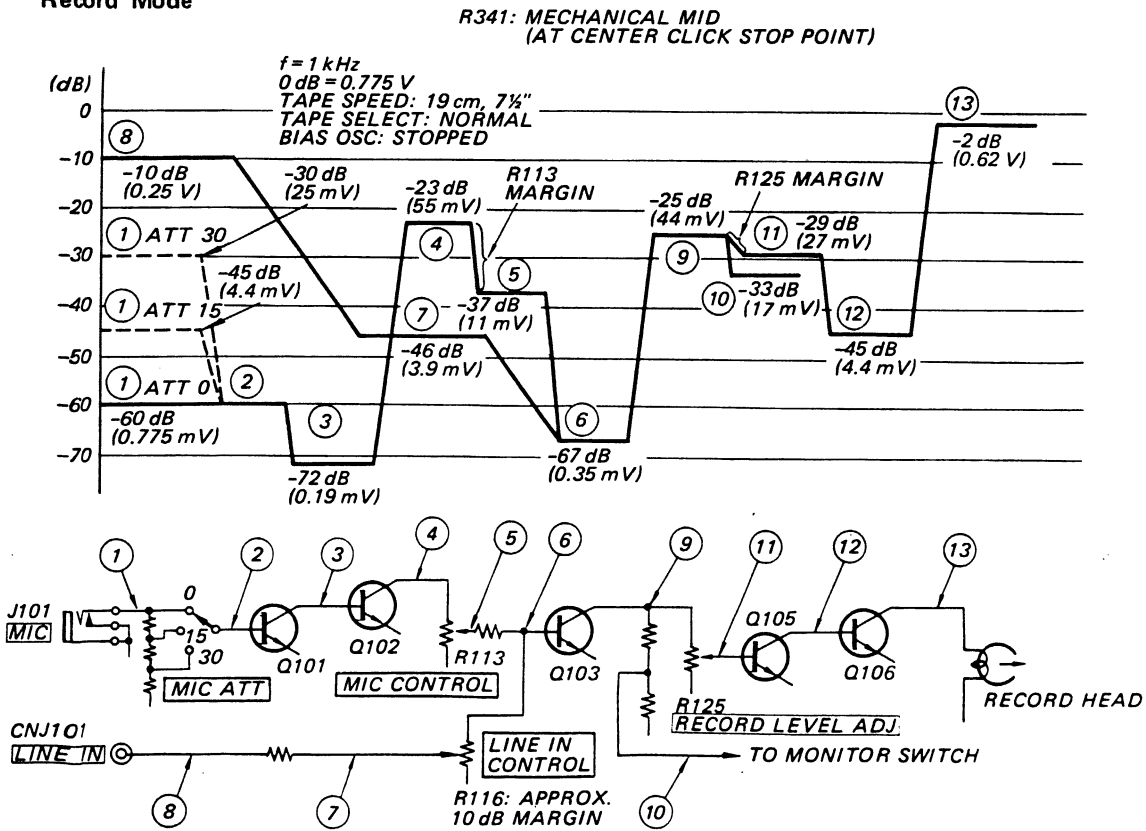

4-2. MOUNTING DIAGRAM (1) - Amplifier Section -

- Conductor Side -

Q101, 201
103, 203:
2SC631A

Q104, 105, 106,
204, 205, 206,
303, 304, 305,
306, 307
403, 404, 405
406, 407
501, 502, 503,
504:
2SC634A

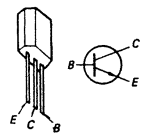

Q102, 202,
302, 402:
2SC1362

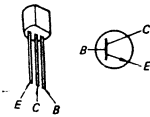

Q301, 401:
2SK43

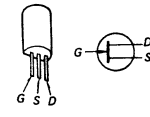

D302, 303,
402, 403:
1T22

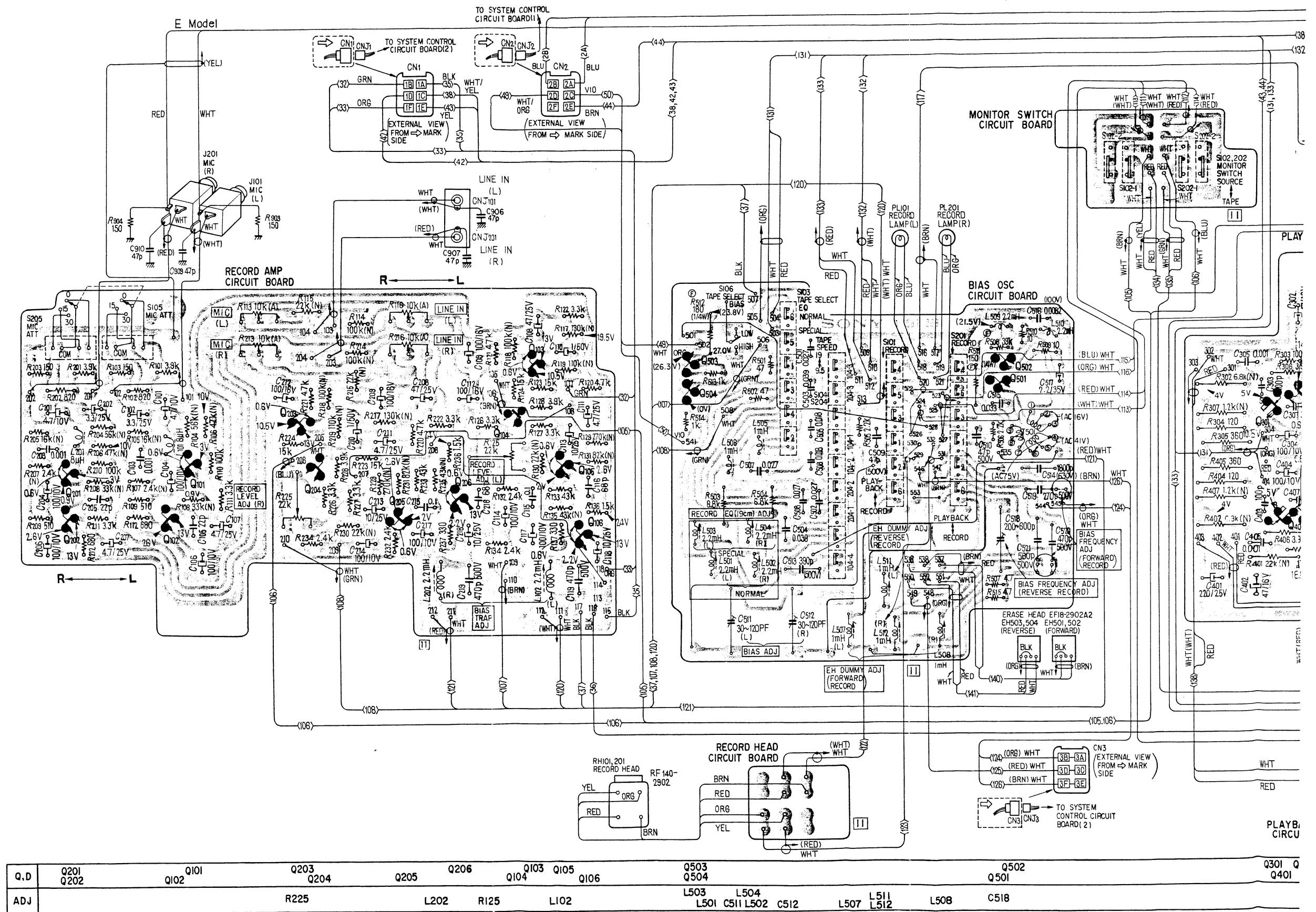
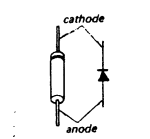

Q.D	Q201 Q202	Q101 Q102	Q203 Q204	Q205	Q206	Q103 Q104	Q105 Q106	Q503 Q504	Q502 Q501	Q301 Q401		
ADJ			R225		L202	R125	L102	L503 L501	C512 L504 L502	L507 L512	L508	C518

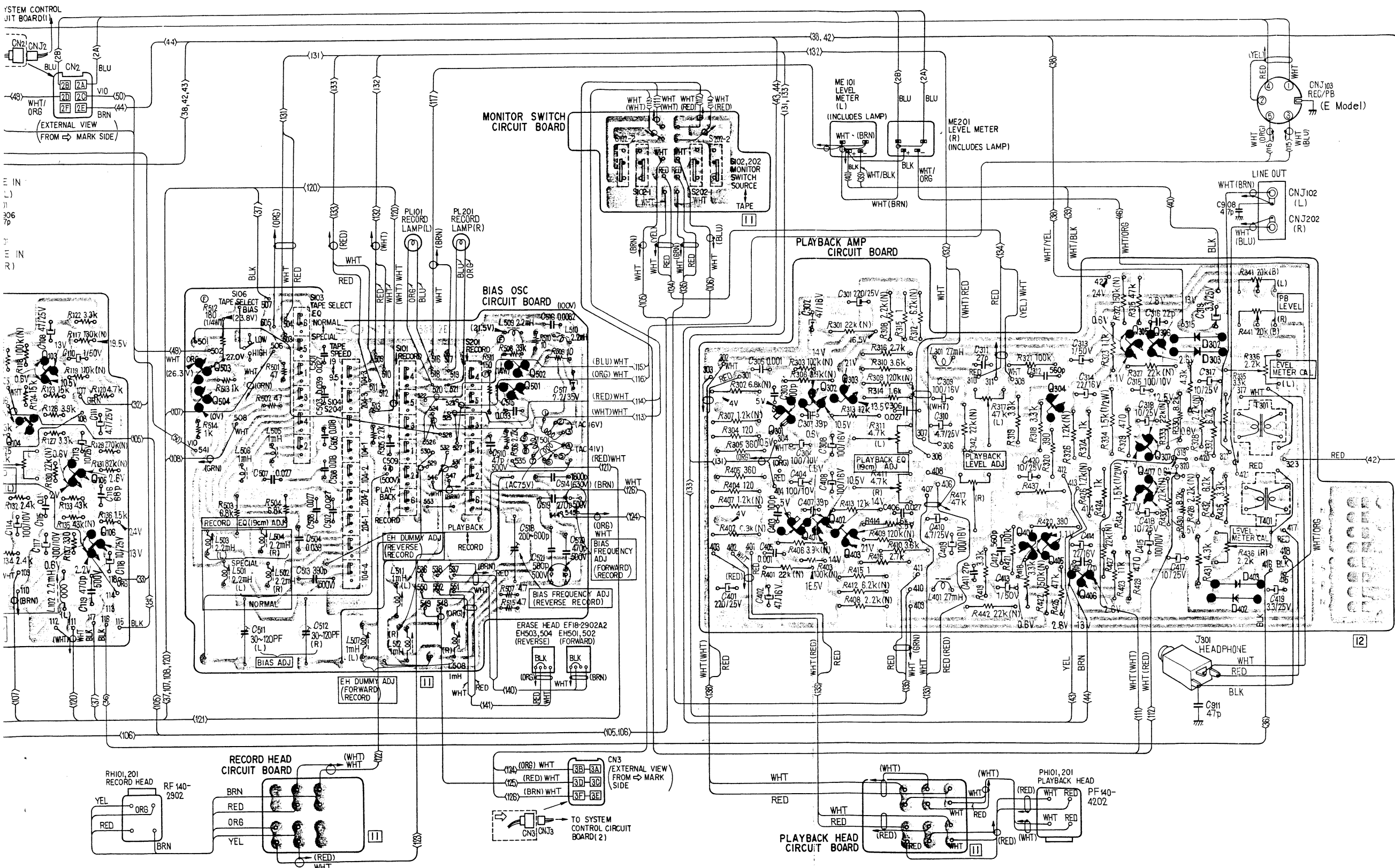

Q104	Q103	Q105	Q106	Q503	Q504	Q501	Q301	Q302	Q303	Q404	Q405	Q406	Q304	Q305	Q306	D302	D403	
				L503	L504	L508	Q401	Q402	Q403	R311	R317	R417	R311	R411	R317	D303	D402	
5		LI02		L501	C511	L502	C512	L507	L512	L508	C518						R336	R436

4-3. SCHEMATIC DIAGRAM (1) — Amplifier Section —

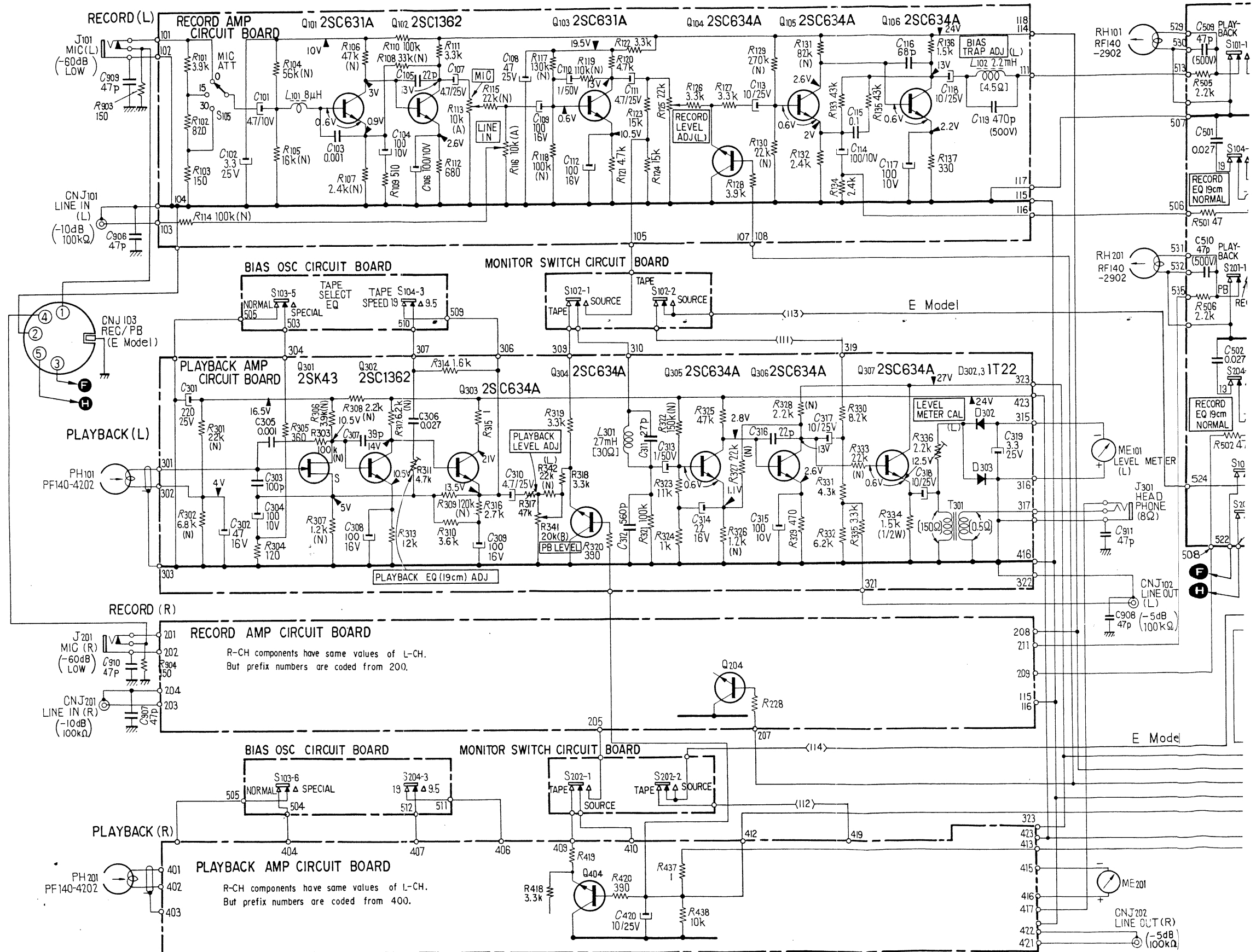

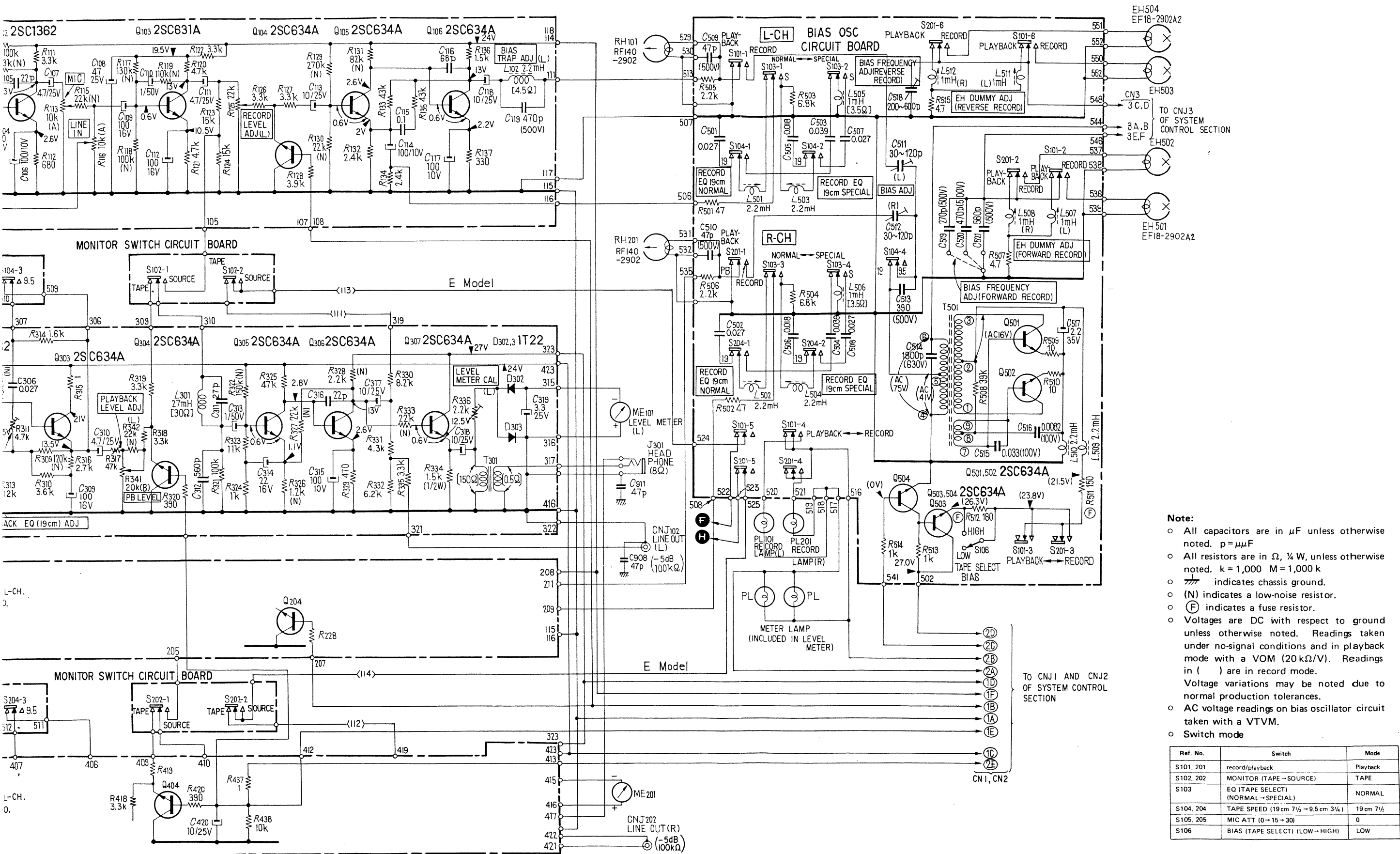

Note:

- All capacitors are in μF unless otherwise noted. $p = \mu\text{F}$
- All resistors are in Ω , $\frac{1}{2} W$, unless otherwise noted. $k = 1,000$ $M = 1,000 k$
- ⊥ indicates chassis ground.
- (N) indicates a low-noise resistor.
- (F) indicates a fuse resistor.
- Voltages are DC with respect to ground unless otherwise noted. Readings taken under no-signal conditions and in playback mode with a VOM (20 $k\Omega/V$). Readings in () are in record mode. Voltage variations may be noted due to normal production tolerances.
- AC voltage readings on bias oscillator circuit taken with a VTVM.
- Switch mode

Ref. No.	Switch	Mode
S101, 201	record/playback	Playback
S102, 202	MONITOR (TAPE → SOURCE)	TAPE
S103	EQ (TAPE SELECT) (NORMAL → SPECIAL)	NORMAL
S104, 204	TAPE SPEED (19 cm 7 1/2 → 9.5 cm 3 1/4)	19 cm 7 1/2
S105, 205	MIC ATT (0 → 15 → 30)	0
S106	BIAS (TAPE SELECT) (LOW → HIGH)	LOW

4.4. MOUNTING DIAGRAM (2) - System Control Section (1) -

- Conductor Side -

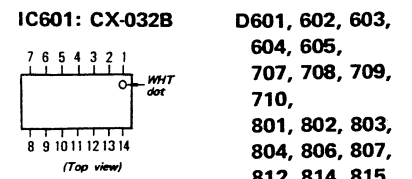

- Q701, 702, 703, 704, 705, 706, 707, 708, 709, 710, 711, 712, 713, 715, 716, 801, 802, 803, 804, 805, 806, 807, 808, 809, 810, 811, 812, 813, 814, 815, 1101, 1102, 1103, 1104, 1105, 1106, 1107, 1108, 1109, 1110, 1111, 1113, 1114, 1115:

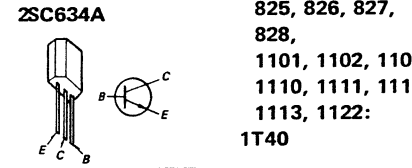

- D701, 711, 712, 808, 810, 811, 825, 826, 827, 828, 1101, 1102, 1109, 1110, 1111, 1112, 1113, 1122:

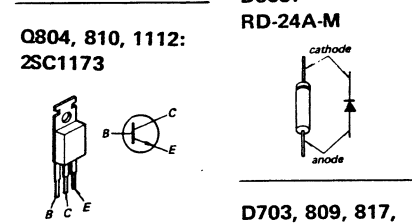

- D702, 705, 706, 813, 1103, 1104, 1105, 1114, 1115, 1118, 1119, 1120, 1121:
- D805:
- Q901, 902:
- Q903, 904:



Q	Q1106	Q1103	Q1105	Q1101	Q1108	Q1113	Q1114	Q1115	Q1001	Q901	Q801
D	D1112	D1111	D1104	D1108	D1121	D1117	D1114	D1115			D801~D8
ADJ											D801

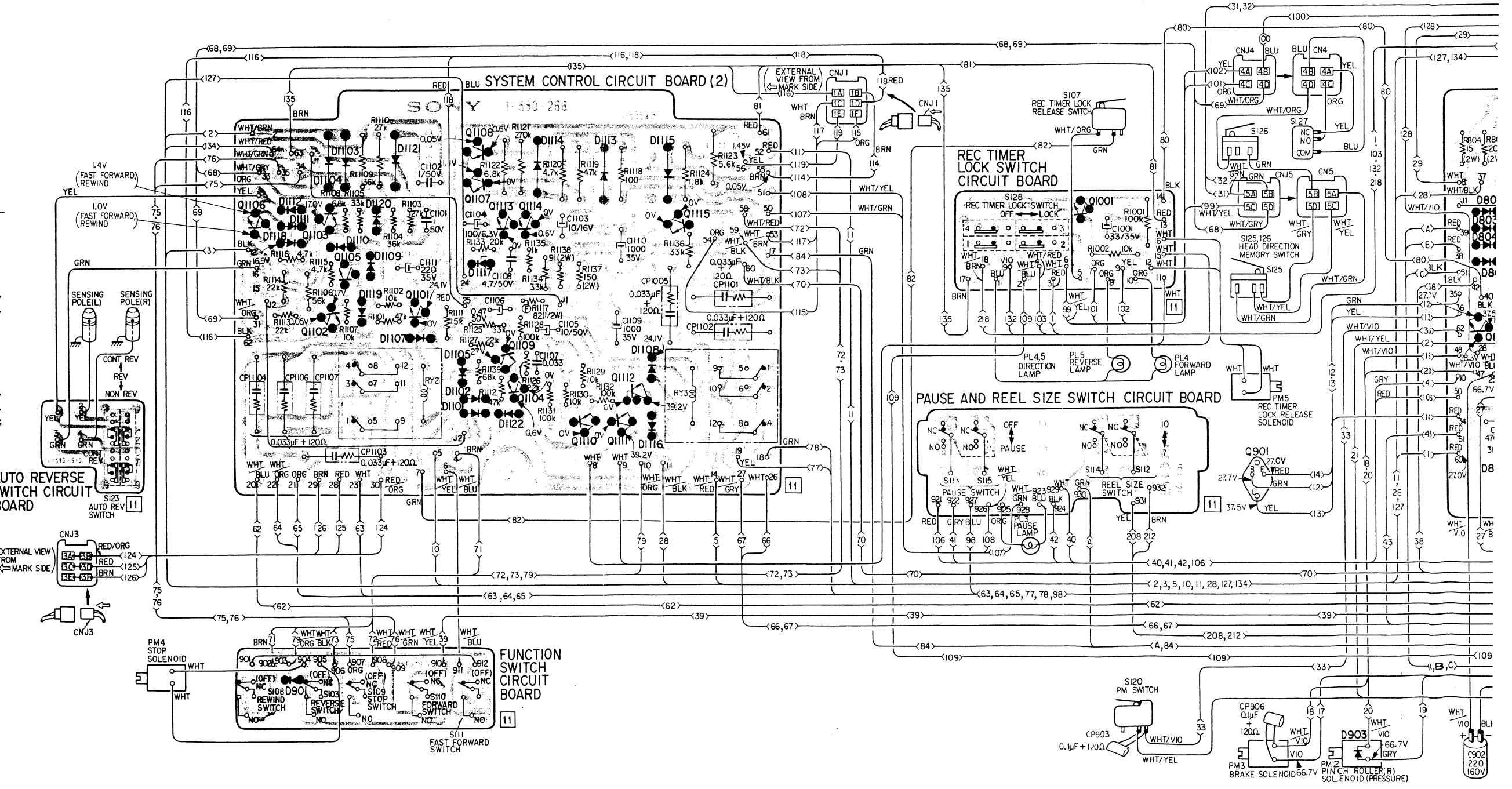

4-5. MOUNTING DIAGRAM (3) - System Control Section (2) -
 - Conductor Side -

Q	Q701	Q715	Q703	Q704	Q707	Q705	Q712	Q706	Q713	Q904	IC601
IC	Q702	Q716			Q708	Q709	Q711	Q710	Q714	Q903	
D		D712	D703	D711	D702	D701	D705	D706	D707~D710	D601	D602~D605
ADJ		R717	R737	R736			R731			R618	R616

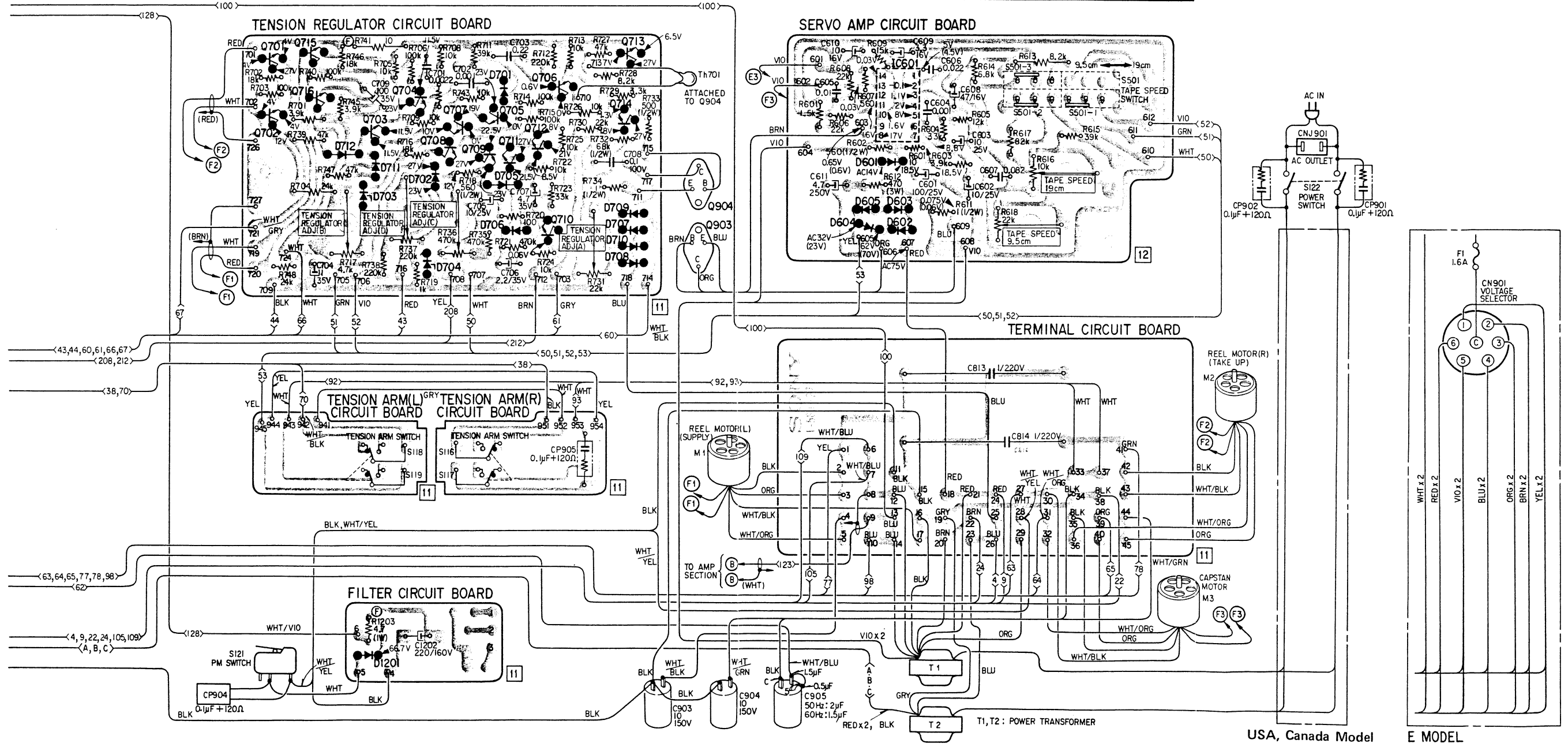

USA, Canada Model

E MODEL

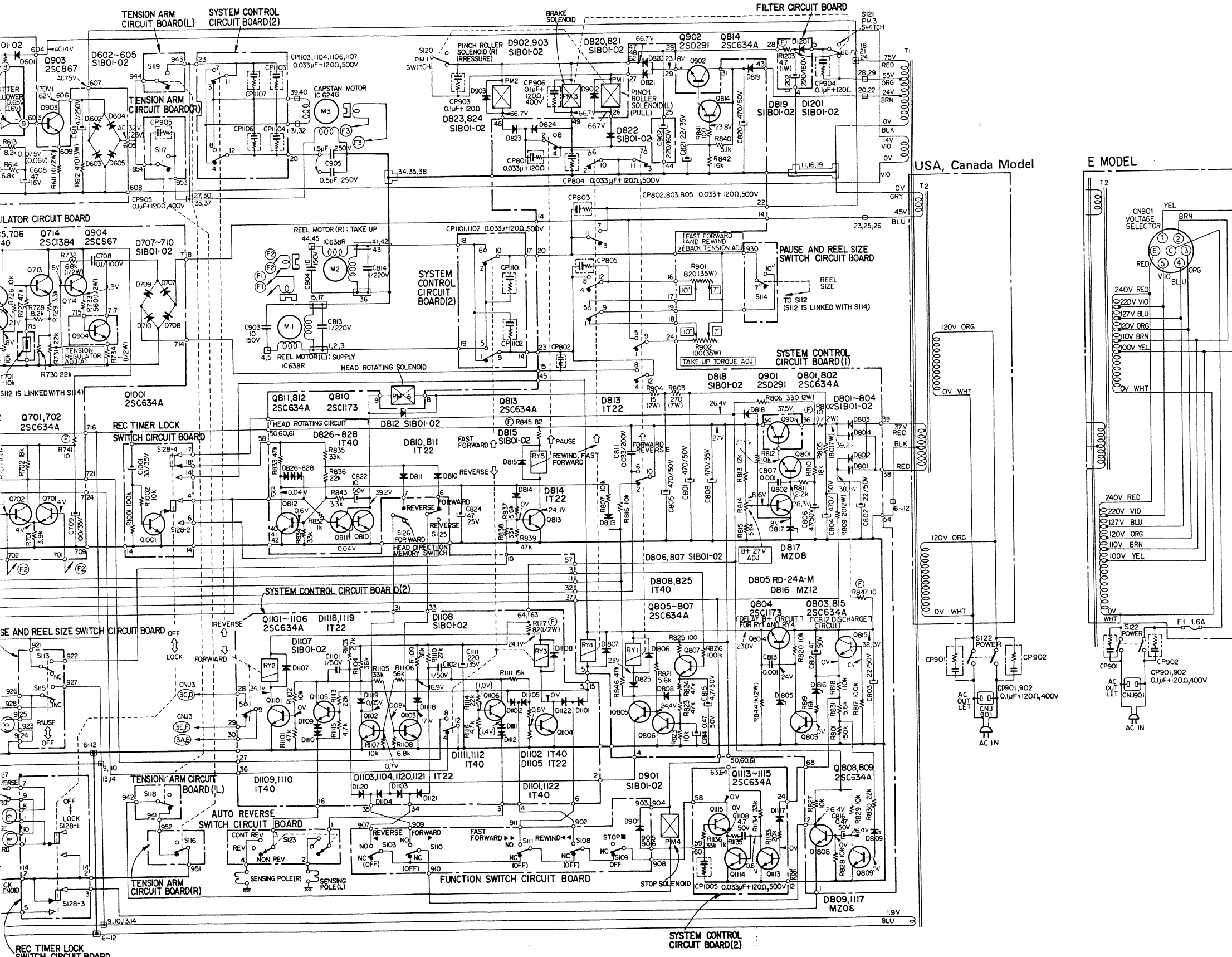

USA, Canada Model

E MODEL

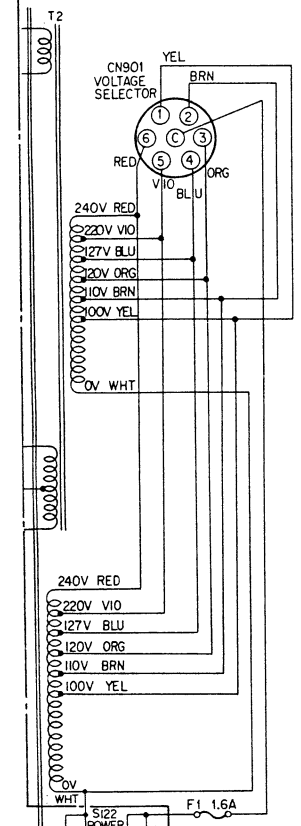

- Note:**
- All capacitors are in μF unless otherwise noted. $\text{p} = \mu\text{F}$
 - All resistors are in Ω , $\frac{1}{4} \text{W}$, unless otherwise noted. $\text{k} = 1,000$ $\text{M} = 1,000 \text{k}$
 - F indicates a fuse resistor.
 - DC resistance (out-of-circuit)
 - PM1, PM2 and PM3 have 240Ω . PM4, PM5 and PM6 have 40Ω .
 - --- indicates chassis ground.
 - Voltage values shown are measured with a VOM (DC: $20 \text{k}\Omega/\text{V}$ AC: $8 \text{k}\Omega/\text{V}$) in stop mode with TAPE SPEED switch to 19 cm $7\frac{1}{2}$ unless otherwise indicated. Voltages in () are for 9.5 cm $3\frac{3}{4}$. Voltage variations may be noted due to normal production tolerances.

○ Switch mode

Ref. No.	Switch	Mode
S103	function, reverse (◄)	OFF
S107	rec timer lock release	OFF
S108	function, rewind (◄◄)	OFF
S109	function, stop (■)	OFF
S110	function, forward (►)	OFF
S111	function, fast forward (►►)	OFF
S112,114	REEL SIZE (7-10½)	7
S113,115	PAUSE	OFF
S116,117	tension arm (R)	OFF
S118,119	tension arm (L)	OFF
S120,121	PM (S120: PM1 drive, S121: PM3 drive)	ON
S122	POWER	OFF
S123	AUTO REV (CONT REV → REV → NON REV)	NON REV
S125,126	head direction memory (forward → reverse)	forward
S127	DIRECTION lamp	forward (▲)
S128	REC TIMER LOCK	release
S501	TAPE SPEED (19 cm $7\frac{1}{2}$ → 9.5 cm $3\frac{3}{4}$)	19 cm $7\frac{1}{2}$

SECTION 5
EXPLODED VIEWS

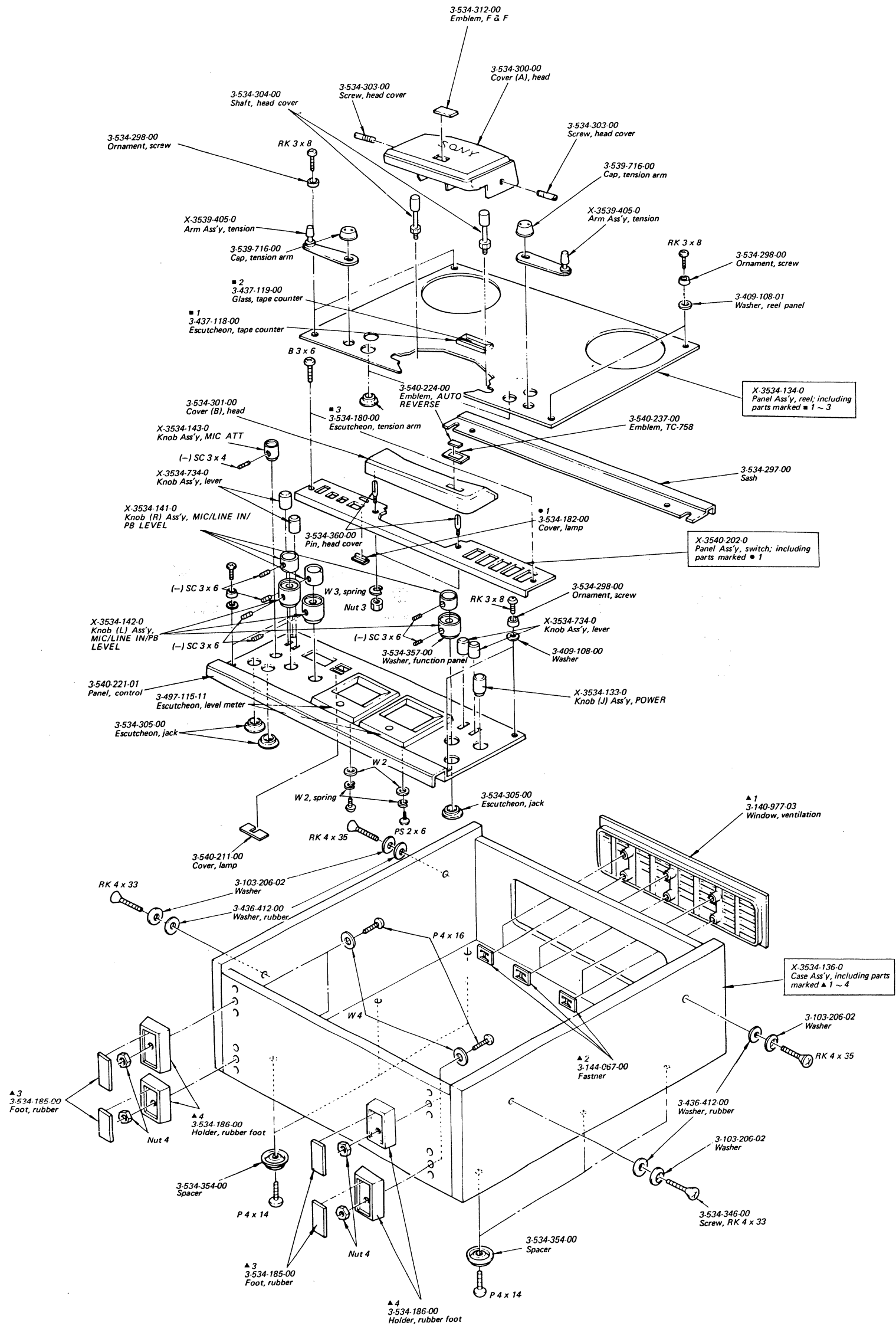

Note: ○ Items without part number and description are not available.
 ○ All screws are Phillips (cross recess) type unless otherwise noted.
 (-) = slotted head

TC-758 TC-758

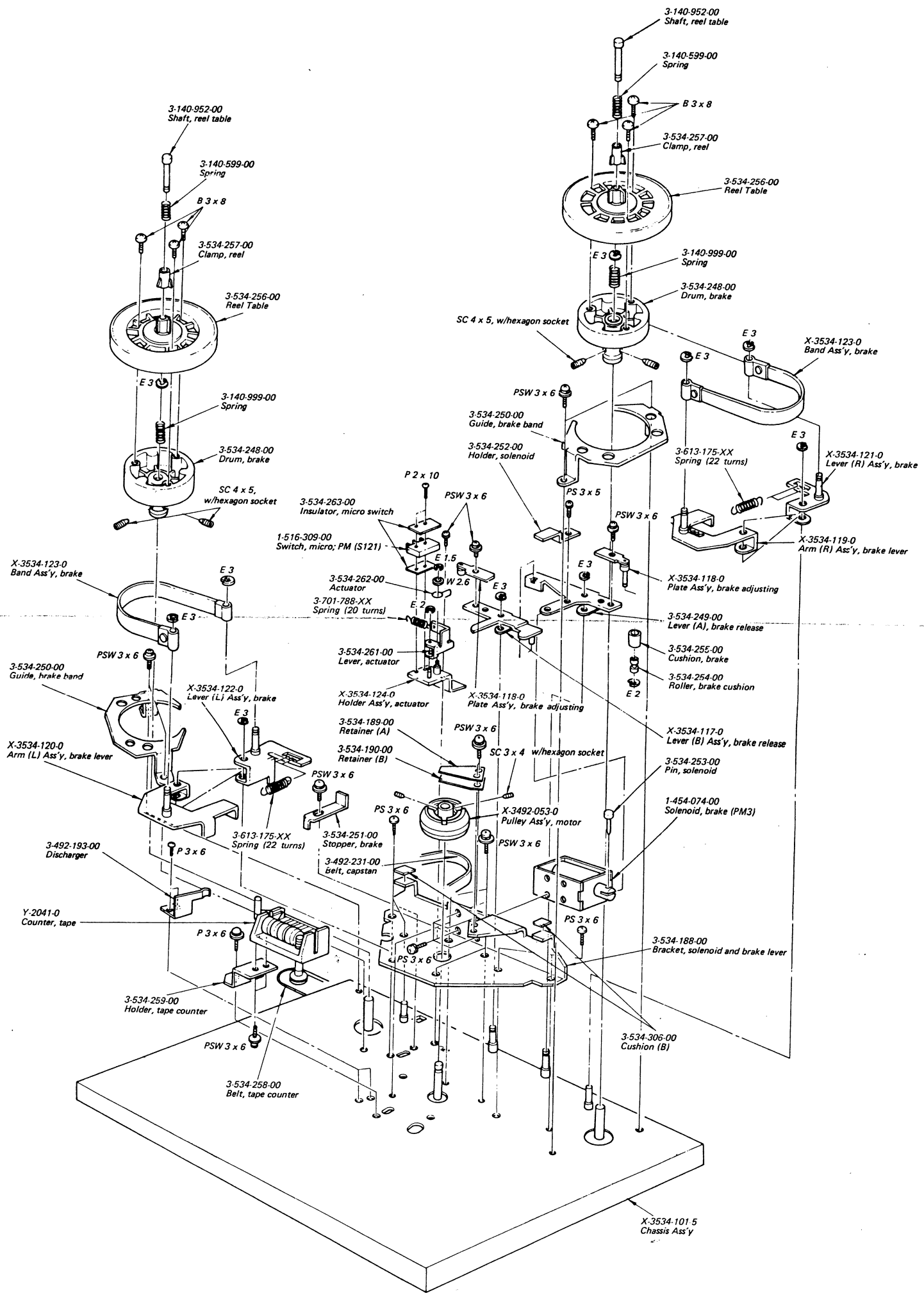

TC-758 TC-758

Note:

- Items without part number and description are not available.
- All screws are Phillips (cross recess) type unless otherwise noted.
- (-) = slotted head

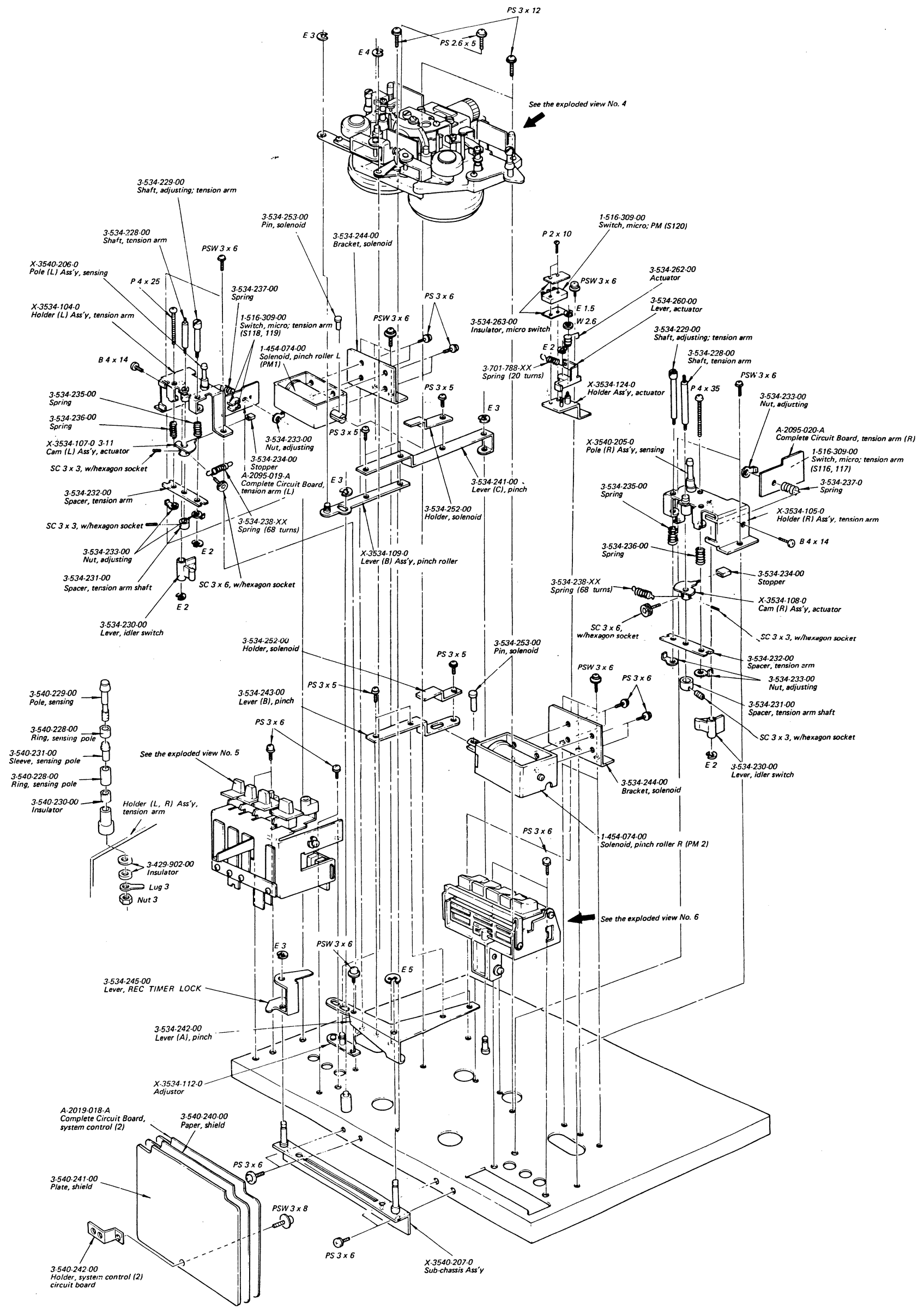

Note: ○ Items without part number and description are not available.
 ○ All screws are Phillips (cross recess) type unless otherwise noted.
 (-) = slotted head

TC-758 TC-758

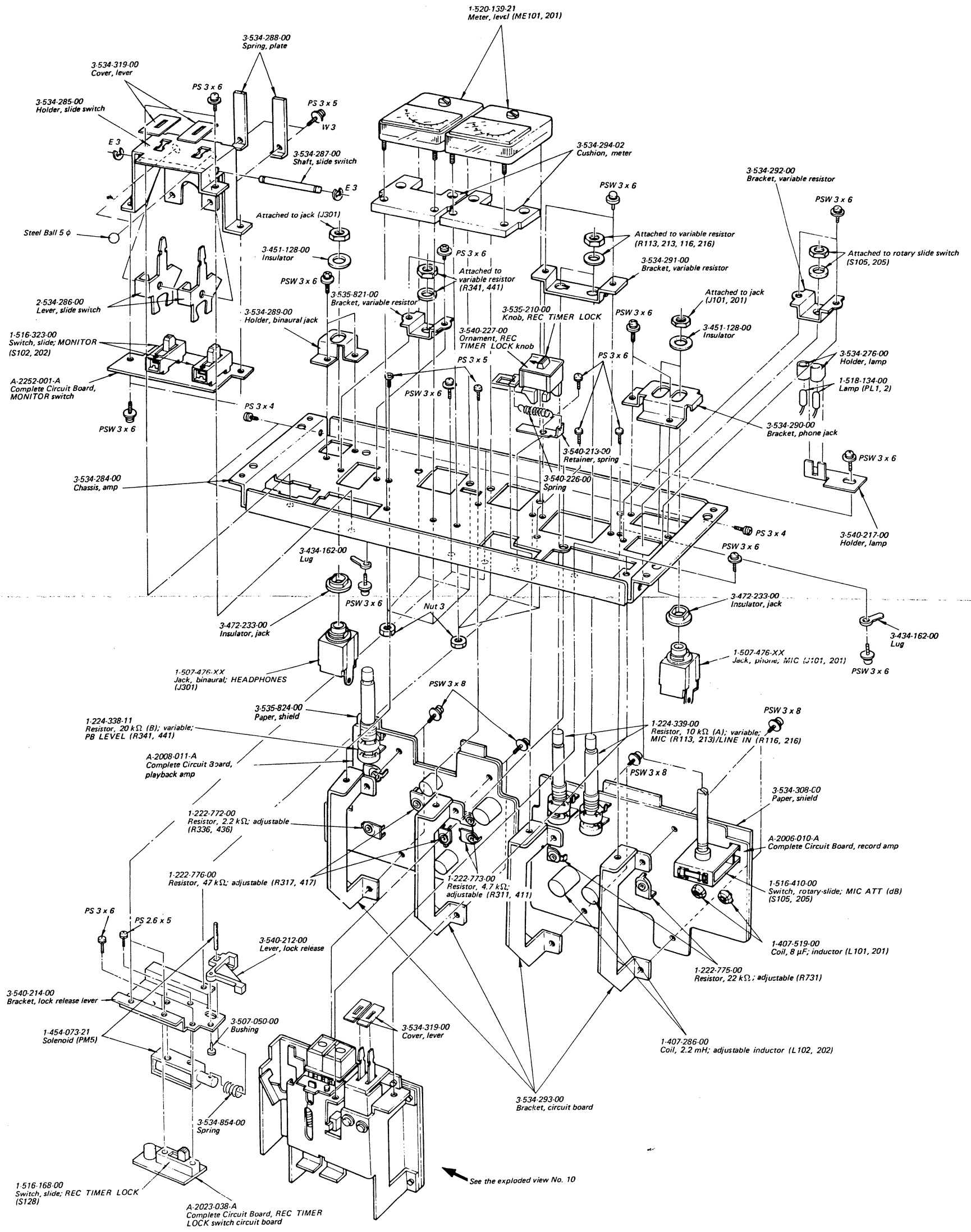

TC-758 TC-758

Note:

- Items without part number and description are not available.
- All screws are Phillips (cross recess) type unless otherwise noted.
- (-) = slotted head

**SECTION 6
ELECTRICAL PARTS LIST**

<u>Ref. No.</u>	<u>Part No.</u>	<u>Description</u>	<u>Ref. No.</u>	<u>Part No.</u>	<u>Description</u>
COMPLETE CIRCUIT BOARDS			Q703~713	Transistor	2SC634A
	A-2006-010-A	Record Amp	Q714	Transistor	2SC1384
	A-2008-011-A	Playback Amp	Q715,716	Transistor	2SC634A
	A-2014-013-A	Bias Osc	Q801~803	Transistor	2SC634A
	A-2019-014-A	Filter	Q804	Transistor	2SC1173
	A-2019-015-A	Tension Regulator	Q805~809	Transistor	2SC634A
	A-2019-016-A	Terminal	Q810	Transistor	2SC1173
	A-2019-017-A	System Control (1)	Q811~815	Transistor	2SC634A
	A-2019-018-A	System Control (2)	Q901,902	Transistor	2SD291
	A-2020-003-A	Servo Amp	Q903,904	Transistor	2SC867
	A-2023-037-A	Auto Rev Switch	Q1001	Transistor	2SC634A
	A-2023-038-A	REC TIMER LOCK Switch	Q1101~1111	Transistor	2SC634A
	A-2023-039-A	Function Switch	Q1112	Transistor	2SC1173
	A-2023-040-A	PAUSE and REEL SIZE Switch	Q1113~1115	Transistor	2SC634A
	A-2095-019-A	Tension Arm (L)	IC601	Integrated Circuit	CX-O32B
	A-2095-020-A	Tension Arm (R)	D302,402	Diode	1T22
	A-2252-001-A	MONITOR Switch	D303,403	Diode	1T22
PRINTED CIRCUIT BOARD			D601~605	Diode	SIB01-02
	1-582-594-00	Head	D701,702	Diode	1T40
SEMICONDUCTORS			D703	Diode	MZ08
Q101,201	Transistor	2SC631A	D704	Diode	MZ12
Q102,202	Transistor	2SC1362	D705,706	Diode	1T22
Q103,203	Transistor	2SC631A	D707~710	Diode	SIB01-02
Q104,204	Transistor	2SC634A	D711,712	Diode	1T40
Q105,205	Transistor	2SC634A	D801~804	Diode	SIB01-02
Q106,206	Transistor	2SC634A	D805	Diode	RD-24A-M
Q301,401	Transistor	2SK43	D806,807	Diode	SIB01-02
Q302,402	Transistor	2SC1362	D808	Diode	1T40
Q303,403	Transistor	2SC634A	D809	Diode	MZ08
Q304,404	Transistor	2SC634A	D810,811	Diode	1T22
Q305,405	Transistor	2SC634A	D812	Diode	SIB01-02
Q306,406	Transistor	2SC634A	D813,814	Diode	1T22
Q307,407	Transistor	2SC634A	D815	Diode	SIB01-02
Q501~504	Transistor	2SC634A	D816	Diode	MZ12
Q701,702	Transistor	2SC634A	D817	Diode	MZ08
			D818~824	Diode	SIB01-02
			D825~828	Diode	1T40
			D901~903	Diode	SIB01-02

<u>Ref. No.</u>	<u>Part No.</u>	<u>Description</u>	
D1101,1102		Diode	1T40
D1103~1105		Diode	1T22
D1107,1108		Diode	SIB01-02
D1109~1113		Diode	1T40
D1114,1115		Diode	1T22
D1116		Diode	SIB01-02
D1117		Diode	MZ08
D1118~1121		Diode	1T22
D1122		Diode	1T40
D1201		Diode	SIB01-02
Th701	1-800-202-00	Thermistor	S-10k

TRANSFORMERS

T1	1-442-194-00	Power (USA, Canada Model)
	1-442-195-00	Power (E Model)
T2	1-442-193-00	Power (USA, Canada Model)
	1-442-196-00	Power (E Model)
T301,401	1-427-299-00	Headphone
T501	1-433-158-00	Bias Osc

COILS

L101,201	1-407-519-00	Inductor, 8 μ H
L102,202	1-407-286-00	Adjustable Inductor, 2.2 mH
L301,401	1-407-593-00	Microinductor, 27 mH
L501~504	1-407-269-00	Adjustable Inductor, 2.2 mH
L505~506	1-407-159-XX	Microinductor, 1 mH
L507,508	1-407-284-00	Adjustable Inductor, 1 mH
L509~510	1-407-198-XX	Microinductor, 2.2 mH
L511,512	1-407-284-00	Adjustable Inductor, 1 mH

CAPACITORS

All capacitors are in μ F unless otherwise indicated.
(p = μ μ F, elect = electrolytic)

C101,201	1-131-192-11	4.7	10V	tantalum
C102,202	1-121-913-11	3.3	25V	elect

<u>Ref. No.</u>	<u>Part No.</u>				<u>Description</u>
C103,203	1-105-821-12	0.001	50V		mylar
C104,204	1-121-414-11	100	10V		elect
C105,205	1-107-115-11	22p	50V		silvered mica
C106,206	1-121-414-11	100	10V		elect
C107,207	1-121-915-11	4.7	25V		elect
C108,208	1-121-410-11	47	25V		elect
C109,209	1-121-415-11	100	16V		elect
C110,210	1-121-391-11	1	50V		elect
C111,211	1-121-915-11	4.7	25V		elect
C112,212	1-121-415-11	100	16V		elect
C113,213	1-121-748-11	10	25V		elect
C114,214	1-121-414-11	100	10V		elect
C115,215	1-105-685-12	0.1	50V		mylar
C116,216	1-107-127-11	68p	50V		silvered mica
C117,217	1-121-414-11	100	10V		elect
C118,218	1-121-398-11	10	25V		elect
C119,219	1-107-016-11	470p	500V		silvered mica
C301,401	1-121-422-11	220	25V		elect
C302,402	1-123-055-11	47	16V		elect
C303,403	1-107-131-11	100p	50V		silvered mica
C304,404	1-123-139-11	100	16V		elect
C305,405	1-105-661-12	0.001	50V		mylar
C306,406	1-105-678-12	0.027	50V		mylar
C307,407	1-107-121-11	39p	50V		silvered mica
C308,408	1-121-415-11	100	16V		elect
C309,409	1-121-415-11	100	16V		elect
C310,410	1-121-915-11	4.7	25V		elect
C311,411	1-107-117-11	27p	50V		silvered mica
C312,412	1-107-246-11	560p	50V		silvered mica
C313,413	1-121-912-11	1	50V		elect
C314,414	1-121-479-11	22	16V		elect
C315,415	1-121-414-11	100	10V		elect
C316,416	1-107-115-11	22p	50V		silvered mica
C317,417	1-121-398-11	10	25V		elect
C318,418	1-121-398-11	10	25V		elect
C319,419	1-121-392-11	3.3	25V		elect
C420	1-121-398-11	10	25V		elect
C501,502	1-105-518-12	0.027	50V		mylar
C503,504	1-105-520-12	0.039	50V		mylar
C505,506	1-105-516-12	0.018	50V		mylar

Ref. No.	Part No.	Description		
C507,508	1-105-518-12	0.027	50V	mylar
C509,510	1-107-163-11	47p	500V	silvered mica
C511,512	1-141-034-21	30~120p		trimmer
C513	1-107-183-11	390p	500V	silvered mica
C514	1-129-705-11	0.0018	630V	polypropylene
C515	1-105-719-12	0.033	100V	mylar
C516	1-105-712-12	0.0082	100V	mylar
C517	1-131-217-11	2.2	35V	tantalum
C518	1-141-155-00	200~600p		trimmer
C519	1-107-179-11	270p	500V	silvered mica
C520	1-107-185-11	470p	500V	silvered mica
C521	1-107-187-11	560p	500V	silvered mica
C601	1-121-935-11	100	25V	elect
C602,603	1-121-398-11	10	25V	elect
C604	1-105-661-12	0.001	50V	mylar
C605	1-105-673-12	0.01	50V	mylar
C606	1-105-677-12	0.022	50V	mylar
C607	1-108-550-11	0.082	50V	polypropylene 5%
C608	1-121-409-11	47	16V	elect
C609,610	1-131-197-11	3.3	16V	tantalum
C611	1-121-900-11	4.7	250V	elect
C701	1-105-665-12	0.0022	50V	mylar
C702	1-105-821-12	0.001	50V	mylar
C703	1-105-529-12	0.22	50V	mylar
C704	1-131-215-11	1	35V	tantalum
C705	1-131-238-11	10	25V	tantalum
C706	1-131-217-11	2.2	35V	tantalum
C707	1-131-219-11	4.7	35V	tantalum
C708	1-105-725-12	0.1	100V	mylar
C709	1-121-357-11	100	35V	elect
C801	1-121-983-11	470	50V	elect
C802,803	1-121-152-11	22	50V	elect
C804,805	1-121-810-11	470	50V	elect
C806	1-121-411-11	47	50V	elect
C807	1-105-821-12	0.001	50V	mylar
C808	1-121-361-11	470	35V	elect
C811	1-105-919-12	0.033	200V	mylar
C812	1-121-411-11	47	50V	elect
C813	1-105-821-12	0.001	50V	mylar
C814	1-121-726-11	0.47	50V	elect

Ref. No.	Part No.	Description		
C815	1-121-396-11	4.7	50V	elect
C816	1-121-726-11	0.47	50V	elect
C820	1-121-983-11	470	50V	elect
C821	1-121-662-11	22	35V	elect
C822	1-121-738-11	10	50V	elect
C824	1-121-410-11	47	25V	elect
C902	1-121-004-11	220	160V	elect
C903,904	1-117-100-11	10	150V	metalized paper
C905	1-117-036-22	1.5+0.5	250V	metalized paper
C906~908	1-107-123-11	47p	50V	silvered mica
C909~911	1-107-123-11	47p	50V	silvered mica
C1001	1-121-652-11	33	35V	elect
C1101,1102	1-121-391-11	1	50V	elect
C1103	1-121-651-11	10	16V	elect
C1104	1-121-413-11	100	6.3V	elect
C1105	1-121-738-11	10	50V	elect
C1106	1-121-726-11	0.47	50V	elect
C1107	1-105-679-12	0.033	50V	mylar
C1108	1-121-954-11	4.7	50V	elect
C1109,1110	1-121-388-11	1000	35V	elect
C1111	1-121-261-11	220	35V	elect
C1202	1-121-004-12	220	160V	elect

RESISTORS

All resistors are in Ω . $\frac{1}{4}W$, $\pm 5\%$ carbon resistors (except particular type) are omitted. Check schematic diagrams for resistance values. (k = 1000 M = 1000 k)

R104,204	1-242-715-09	56k, low noise
R105,205	1-242-702-09	16k, low noise
R106,206	1-242-713-09	47k, low noise
R107,207	1-242-682-09	2.4k, low noise
R108,208	1-242-709-09	33k, low noise
R113,213	1-224-339-00	10k (A), variable; MIC
R114,214	1-242-721-09	100k, low noise
R115,215	1-242-705-09	22k, low noise
R116,216	1-222-339-00	10k (A), variable; LINE IN
R117,217	1-242-724-09	130k, low noise
R118,218	1-242-721-09	100k, low noise

<u>Ref. No.</u>	<u>Part No.</u>	<u>Description</u>
R119,219	1-242-722-09	110k, low noise
R125,225	1-222-775-00	22k, adjustable
R129,229	1-242-731-09	270k, low noise
R130,230	1-242-705-09	22k, low noise
R131,231	1-242-719-09	82k, low noise
R301,401	1-244-705-09	22k, low noise
R302,402	1-244-693-09	6.8k, low noise
R303,403	1-242-721-09	100k, low noise
R306,406	1-244-687-09	3.9k, low noise
R307,407	1-244-675-09	1.2k, low noise
R308,408	1-244-681-09	2.2k, low noise
R309,409	1-244-723-09	120k, low noise
R311,411	1-222-773-00	4.7k, adjustable
R312,412	1-244-692-09	6.2k, low noise
R317,417	1-222-776-00	47k, adjustable
R322,422	1-244-725-09	150k, low noise
R326,426	1-244-675-09	1.2k, low noise
R327,427	1-244-705-09	22k, low noise
R328,428	1-244-681-09	2.2k, low noise
R333,433	1-244-705-09	22k, low noise
R334,434	1-244-877-11	1.5k, ½W
R336,436	1-222-772-00	2.2k, adjustable
R341,441	1-224-338-00	20k (B), variable; PB LEVEL
R342,442	1-244-705-09	22k, low noise
R511	1-217-401-11	150, fuse
R512	1-217-402-11	180, fuse
R602	1-244-867-11	560 ½W
R611	1-244-801-11	1 ½W
R612	1-206-717-11	470 3W, metal oxide
R616	1-222-774-00	10k, adjustable
R618	1-222-775-00	22k, adjustable
R717	1-222-773-11	4.7k, adjustable
R731	1-222-775-00	22k, adjustable
R732	1-242-717-11	68k ½W
R733	1-244-867-11	560 ½W
R734	1-244-801-11	1 ½W
R736	1-222-779-00	470k, adjustable
R737	1-222-778-00	220k, adjustable
R741	1-217-387-11	10 ¼W, fuse

<u>Ref. No.</u>	<u>Part No.</u>	<u>Description</u>
R802	1-217-434-11	10 ½W, fuse
R803	1-207-944-11	270 7W, wirewound
R804	1-206-467-11	15 2W, metal oxide
R805	1-207-992-11	180 7W, wirewound
R806	1-207-639-11	330 2W, wirewound
R809	1-206-470-11	20 2W, metal oxide
R814	1-222-771-00	1k, adjustable
R844	1-206-664-11	1k 2W, metal oxide
R845	1-217-398-11	82 ¼W, fuse
R847	1-217-387-11	10 ¼W, fuse
R901	1-223-094-31	820 35W, adjustable, wirewound
R902	1-223-101-11	100 35W, adjustable, wirewound
R1117	1-217-398-11	82 ½W, fuse
R1137	1-206-644-11	150 2W
R1138	1-206-486-11	91 2W
R1203	1-217-477-11	4.7 1W, fuse

SWITCHES

S101,201	1-516-367-00	Slide, record/playback
S102,202	1-516-323-00	Slide, MONITOR
S103	1-516-367-00 1-514-730-00	Slide, EQ (TAPE SELECT) Micro, function
S104,204	1-514-976-21	Slide, TAPE SPEED
S105,205	1-516-410-00	Rotary-slide, MIC ATT (dB)
S106	1-516-325-12	Micro, BIAS (TAPE SELECT)
S107	1-514-722-21	Micro, record timer lock release
S108~111	1-514-730-00	Micro, function
S112~115	1-516-325-00	Micro, PAUSE and REEL SIZE
S116~119	1-516-309-00	Micro, tension arm
S120	1-516-309-00	Micro, PM1
S121	1-516-309-00	Micro, PM3
S122	1-516-181-00	Push, POWER
S123	1-514-323-00	Slide, AUTO REV
S125~127	1-516-383-00	Micro, head direction memory
S128	1-516-168-11	Slide, REC TIMER LOCK
S501	1-514-673-00	Slide, TAPE SPEED

Ref. No. Part No. Description

JACKS

J101,201	1-507-476-XX	Phone, MIC L, R
J301	1-507-476-XX	Binaural, HEADPHONES
CNJ101,201	1-507-378-XX	Phono, 2p; LINE IN
CNJ102,202	1-507-378-XX	Phono, 2p; LINE OUT
CNJ103	1-509-359-00	Connector, REC/PB (E Model)
CNJ901	1-509-341-13	Connector, AC OUTLET
CN901	1-509-427-11	Socket, voltage selector (E Model)
CN1,CNJ1	1-931-262-12	Connector, AMPLOK; w/harness
CN5,CNJ5		

ENCAPSULATED COMPONENTS, C-R

CP801~805	1-231-057-31	0.033 μ F + 120 Ω	500 V
CP901~906	1-101-534-31	0.1 μ F + 120 Ω	400 V
CP1101~			
1107	1-231-057-31	0.033 μ F + 120 Ω	500 V

MISCELLANEOUS

EH501~504	8-825-547-00	Head, erase; EF18-2902A2
F1	1-532-137-00	Fuse 1.6A (E Model)
M1,2	8-832-638-01	Motor, reel; IC-638R
M3	8-832-624-24	Motor, capstan
ME101,102	1-520-139-21	Meter, level
PH101,201	8-825-534-00	Head, playback; PF140-4202
PL1~5	1-518-134-00	Lamp, 2 V 0.1A
PM1	1-454-074-00	Solenoid, pinch roller (L)
PM2	1-454-074-00	Solenoid, pinch roller (R)
PM3	1-454-074-00	Solenoid, brake
PM4	1-454-073-22	Solenoid, stop
PM5	1-454-073-21	Solenoid, record timer lock release
PM6	1-454-073-22	Solenoid, head rotating
RY1~5	1-515-127-41	Relay
RH101,201	8-825-511-00	Head, record; PF140-2902
	1-452-072-00	Ring, magnet
	1-533-007-11	Holder, fuse (E Model)
	1-534-487-23	Cord, power (E Model)
	1-534-538-21	Cord, power (USA, Canada Model)
	1-536-395-00	Terminal Strip 1L1

ACCESSORIES & PACKING MATERIALS

<u>Part No.</u>	<u>Description</u>
X-3141-019-0	Adaptor Ass'y, 10" reel
X-3534-138-0	Reel Ass'y, R-11B
X-3701-018-2	Cleaning Tips (E, Canada Model)
1-534-049-31	Cord, connection; RK-74
3-401-193-00	Tape, head cleaning (USA Model)
3-534-324-00	Cushion, upper
3-534-325-00	Cushion, lower
3-540-245-00	Carton
3-701-020-20	Bag, polyethylene
3-701-031-00	Envelope, IBM card (USA Model)
3-701-186-00	Bag, IBM card (USA Model)
3-701-356-00	Label, tack (Canada Model)
3-701-362-00	Label, tack
3-701-646-00	Bag, polyethylene
3-701-673-00	Card, quality control (USA Model)
3-780-499-61	Manual, instruction (E Model)
3-780-499-21	Manual, instruction (USA Model)
3-780-499-31	Manual, instruction (Canada Model)
3-793-010-20	Booklet, tape talk
3-793-044-00	Label, carton important (USA Model)
3-793-124-13	Leaflet, head caution
3-793-359-11	Card, voltage
3-793-711-11	Label, caution (Canada Model)
3-793-848-31	Leaflet (Canada Model)

